

WS2HF & WS3 2-3" Control Valves

**Installation Instructions
& Owner's Manual**

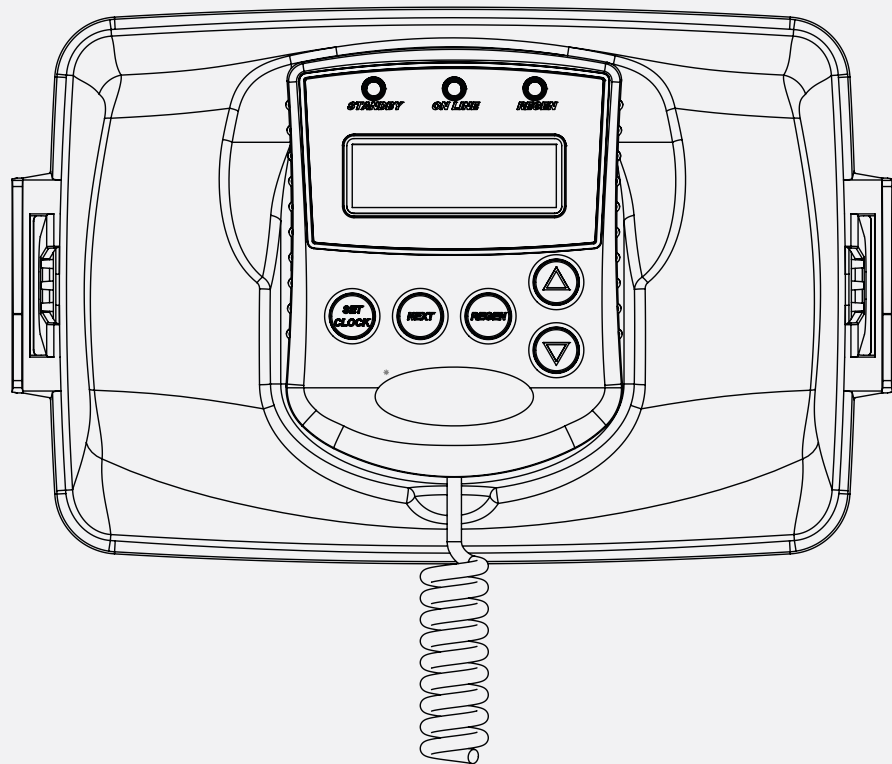

WARNING: USE ONLY SILICONE-BASED LUBRICANTS ON ALL COMMERCIAL COMPONENTS
HYDROCARBONS WILL DAMAGE COMPONENTS THAT CONTAIN O-RINGS AND/OR PLASTIC. THIS CAN CAUSE
LEAKS OR BREAKAGE. DO NOT USE LUBRICANTS THAT CONTAIN HYDROCARBONS SUCH AS PETROLEUM JELLY.
DO NOT USE CONTROL VALVE PRODUCTS ON WATER SUPPLIES THAT
CONTAIN HYDROCARBONS, SUCH AS BENZENE, GASOLINE, KEROSENE, ETC.

Table of Contents

General Specifications and Pre-Installation Checklist	4
Wiring for Custom Power Adapter.....	5
Custom Meter Wiring	5
Main PC Board.....	6
V4427 Relay Expansion Board.....	7
Typical System Examples	8
Button Function and Programming Key Sequence.....	10
Programming Quick Reference.....	11
Typical User Screens	13
Setting Time of Day and Date.....	15
Notifications	15
Errors	15
System Setup Screens	16
Cycle Setup Screens	21
Expansion Setup Screens	23
Installer Setup Screens	26
Diagnostic Screens.....	28
Valve History.....	31
Custom Auxiliary Output Drive Timing	32
Modbus Information	34
Installation.....	37
Installation Summary.....	42
Cycle Positions / Flow Diagrams	43
Front Cover and Drive Assembly	46
Drive Cap Assembly, Downflow Piston, Regenerant Piston, Spacer Stack Assembly, Drive Backplate and Main Body	47
Inline Flow Meter Assembly	48
WS2H, WS2HF, and WS3 Brine Valve Body and Injector Components ...	49
Standard Injector Graphs	50
Bases.....	52
Drain Line Flow Controls.....	53
WS2H, WS2HF, and WS3 Troubleshooting Guide	57
Warranty	67

General Specifications

Minimum/Maximum Operating Pressures	20 psi (138 kPa) -125 psi (862 kPa)		
Minimum/Maximum Operating Temperatures	40°F (4°C) – 110°F (43°C)		
Power Adapter: Supply Voltage Supply Frequency Output Voltage Output Current	U.S. and International 120/230 VAC 50/60 Hz 24 VDC (see Table 2) 800 mA		
No user serviceable parts are on the PC board, the motor, or the Power adapter. The means of disconnection from the main power supply is by unplugging the Power adapter from the wall.			
Service flow rate	WS2H Valve: 125 gpm (473 lpm, 28.4 m³/h) @ 15 psig (103 kPa) drop WS2HF Valve: 165 gpm (625 lpm, 37.5 m³/h) @ 15 psig (103 kPa) drop WS3 Valve: 250 gpm (946 lpm, 56.8 m³/h) @ 15 psig (103 kPa) drop		
Backwash flow rate	WS2H Valve: 125 gpm (473 lpm, 28.4 m³/h) @ 25 psig (172 kPa) drop WS2HF Valve: 175 gpm (662 lpm, 39.8 m³/h) @ 25 psig (172 kPa) drop WS3 Valve: 220 gpm (833 lpm, 50.0 m³/h) @ 25 psig (172 kPa) drop		
CV Service	WS2H Valve: 32.3 WS2HF Valve: 42.6 WS3 Valve: 64.6		
CV Backwash	WS2H Valve: 25.0 WS2HF Valve: 35.0 WS3 Valve: 44.0		
Meter: Accuracy: Flow Range:	WS2" Valves + 5 % 1.5 – 125 gpm (5.7 – 473 lpm)	WS3 Valve: Optional External Meter + 5 % 3.5 – 350 gpm(13.3 – 1325 lpm)	
Regenerant Refill Rate	Variable - Shipped from Factory with 2.2 gpm (8.33 lpm)		
Injectors	See Injector Graphs V3010-2A through 2H		
Brine Line Adapters Included	1" Male NPT Elbow & ¾" x 1" Solvent Weld Elbow		
Inlet, Outlet and Drain Line Openings	2" Valves: 2" Female NPT or BSPT 3" Valves: 3" Female NPT or BSPT		
*Distributor Tube Sizing:	Female NPT Inlet & Outlet		Female BSPT Inlet & Outlet
2" Valves	2.375" OD (2.0" NPS)	+2.25" - +2.5"	63 mm OD
3" Valves	3.5" OD (3" NPS)	+2.5" – 2.75"	90 mm OD
Tank Connection: 2" Valves 3" Valves	4"-8UN, 6" Flange, Side Mount (2" Female NPT or BSPT) 6" Flange or Side Mount (3" Female NPT or BSPT)		
Shipping Weight	WS2H Valve with Meter: 50 lbs. (22.7 kg) WS2HF: 48 lbs. (21.8 kg) Meter Sold Separately WS3 Valve: 57 lbs. (25.9 kg) Meter Sold Separately		
PC Board Memory	Nonvolatile EEPROM (electrically erasable programmable read only memory)		
Compatible with the following typical concentrations of regenerants/chemicals	Sodium chloride, potassium chloride, potassium permanganate, sodium bisulfite, chlorine and chloramines		

*Height is based off the top of tank. Installer to verify proper engagement and allowance for tank expansion.

CUSTOM POWER ADAPTER

1. Cable should be one unshielded pair of 22AWG, UV resistant UL2464 compliant wire.
2. Connector details:
 - a. Terminate end with one Hirose black housing, P/N DF3-4S-2C and four Hirose pins, P/N DF3-22SC.
 - b. Pin 1 = Ground from power supply (Black)
Pin 2 = Jumper to Pin 3
Pin 3 = Jumper to Pin 2
Pin 4 = 24 VDC from power supply (White)

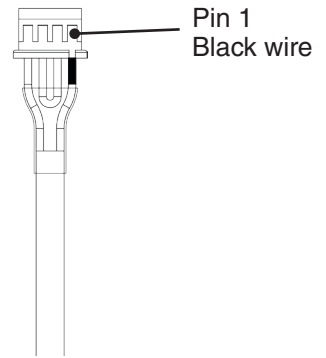

CUSTOM METER

- 1) Terminate end with a Molex series 2695 housing, part number 22-01-3037 and (3) Molex series 41572 (or 40445) pins, part number 08-65-0805 (or 97-00-44).
- 2) Auxilliary meter must be able to operate on 5VDC
Pin 1 = +5 VDC
Pin 2 (Center) = Signal
Pin 3 = Ground
- 3) Acceptable pulse input is 0.1 – 999 pulses/gallon, or 0.4 –519 pulses / liter.

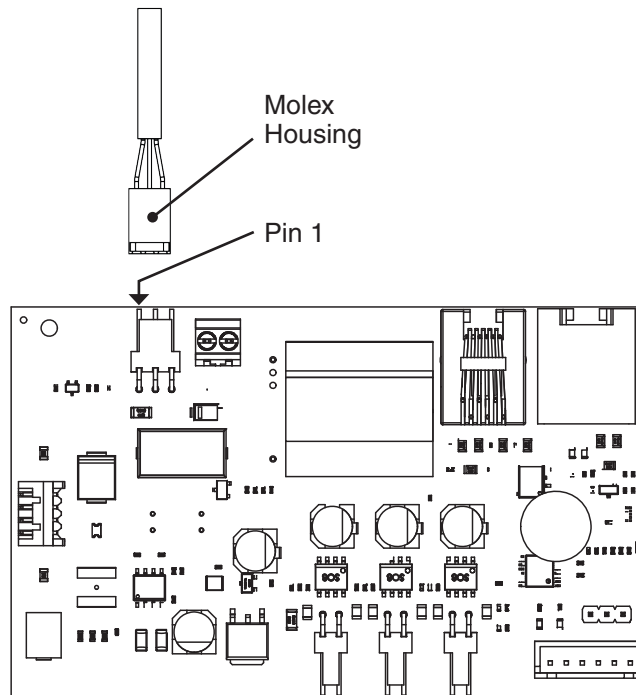

Board Installation

MAIN PC BOARD

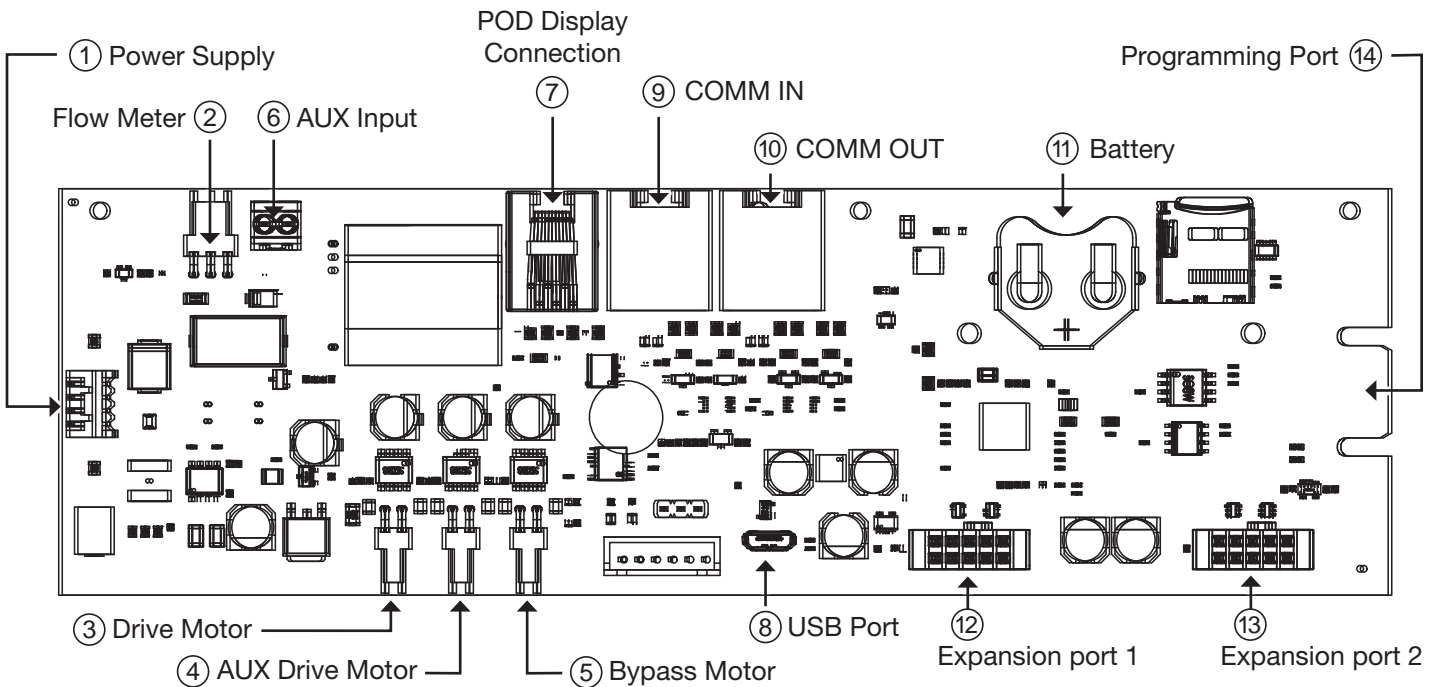

Item	Board label	Description
1	POWER	Connect to proper power supply
2	FLOW	Input for the unit's flow meter
3	REGEN	Motor circuit used to power the main drive of the unit during regeneration
4	AUX DRIVE	2nd Drive circuit for factory motorized isolating valve (MAV or NoHBP)
5	BYPASS	Drive circuit for factory motorized isolating valve (MAV or NoHBP)
6	AUX IN	Connect to external dry contacts to control functionality based on the unit's settings **Wiring units inputs in parallel requires matching each units polarity**
7	DISPLAY	Connection for POD display
8	USB	USB connection for future use. Must use adapter cable to convert from micro-USB connection to USB female adapter
9	COMM IN/MODBUS	RJ45 communication port for communication to LEAD or previous LAG. Must use straight through RJ45 cable with T-568B wiring for communication to LEAD or previous LAG. If setup as LEAD, can be used for Modbus communication with proper cable wiring and RS485 communication adapter.
10	COMM OUT	RJ45 communication port for communication to LAG units. Must use straight through RJ45 cable with T-568B wiring for communication to LAG.
11	BAT1	CR2032 battery for keeping clock powered during power loss
12	EXP1	Connection for the optional expansion boards
13	EXP2	Connection for the optional expansion boards
14	DATA	Factory use only

Board Installation

V4427 WS2H/3 RELAY EXPANSION BOARD

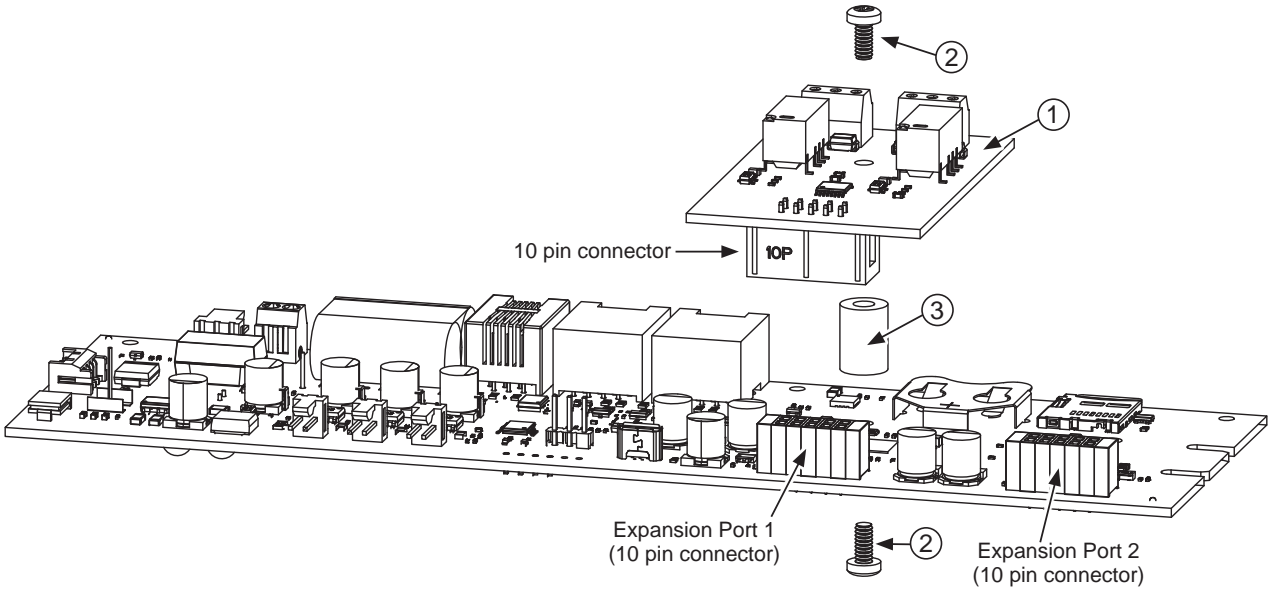

Item	Part No:	Quantity	Description:
1	V4338	1	WS2H/3 PCB RELAY EXPANSION
2	V4425	2	NYLON PHILLIPS SCREW 4-40X.250"
3	V4426	1	NYLON HEX STANDOFF 4-40X1/2"

- Using the nylon standoff (3) and one of the nylon screws (2), attach the standoff to the valve board (V3242-02) in the hole for either Expansion Port 1 or Expansion Port 2 and hand tighten. See figures above.
- Attach the relay expansion board (1) 10-pin connector to the valve board expansion port with the nylon standoff.
- Using the remaining nylon screw (2), insert the screw through the expansion board mounting hole and into the standoff and lightly tighten using a small Phillips screwdriver.
- Follow the instructions under "Expansion Setup Screens" to setup the relay board as needed. See the figure for connector locations on relay expansion board.

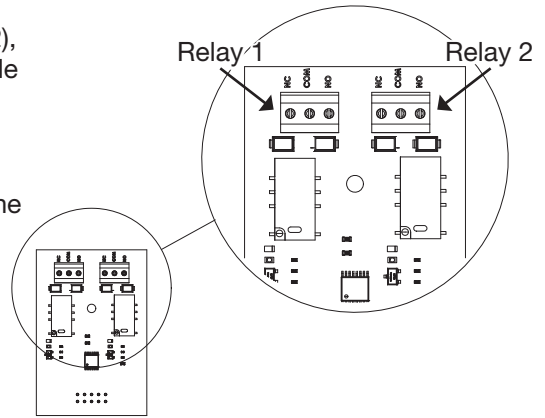

Relay Specs	
Contact Type:	Dry
Amp Draw Max:	1 amp
VDC Max:	30
VAC Max:	30

System Examples

TWIN TANK SYSTEM, SIMPLE ALTERNATOR (SHARING A MAV)

System consists of 2 power heads, 1 communication cable and 1 MAV

Electrical Connections:

- The MAV's motor wire is connected to the 2-pin connector labeled BYPASS on Unit 2 (Unit B) PC board
- Using a standard straight through RJ45 cable (T-568B wiring), connect the "COMM OUT" of the LEAD control to the "COMM IN" of the LAG control (See Page 6 for connector locations)
- If a single external Clack Meter is used, it should be connected to the 3-pin connector on Unit 2 (Unit B) labeled FLOW. NOTE: You should select 2" System Meter or 3" System Meter for the size you are using. When using a single non- Clack external meter, you should select "SYSTEM PULSES" and the proper pulse rate must be selected in the programming section.

Plumbing Connections:

- To regenerate with raw/untreated water, the outlet of each unit is piped to the MAV. Port A will be piped to the LEAD (Unit A) , Port B to the LAG (Unit B), and Port C to the common supply outlet.
- To regenerate with soft/treated water, the inlet of each unit is piped to the MAV. Port A will be piped to the LEAD (Unit A), Port B to the LAG (Unit B) and Port C to the common supply outlet.

If the piston rod is not visible, the current path of flow is between the "A" and "C" ports.

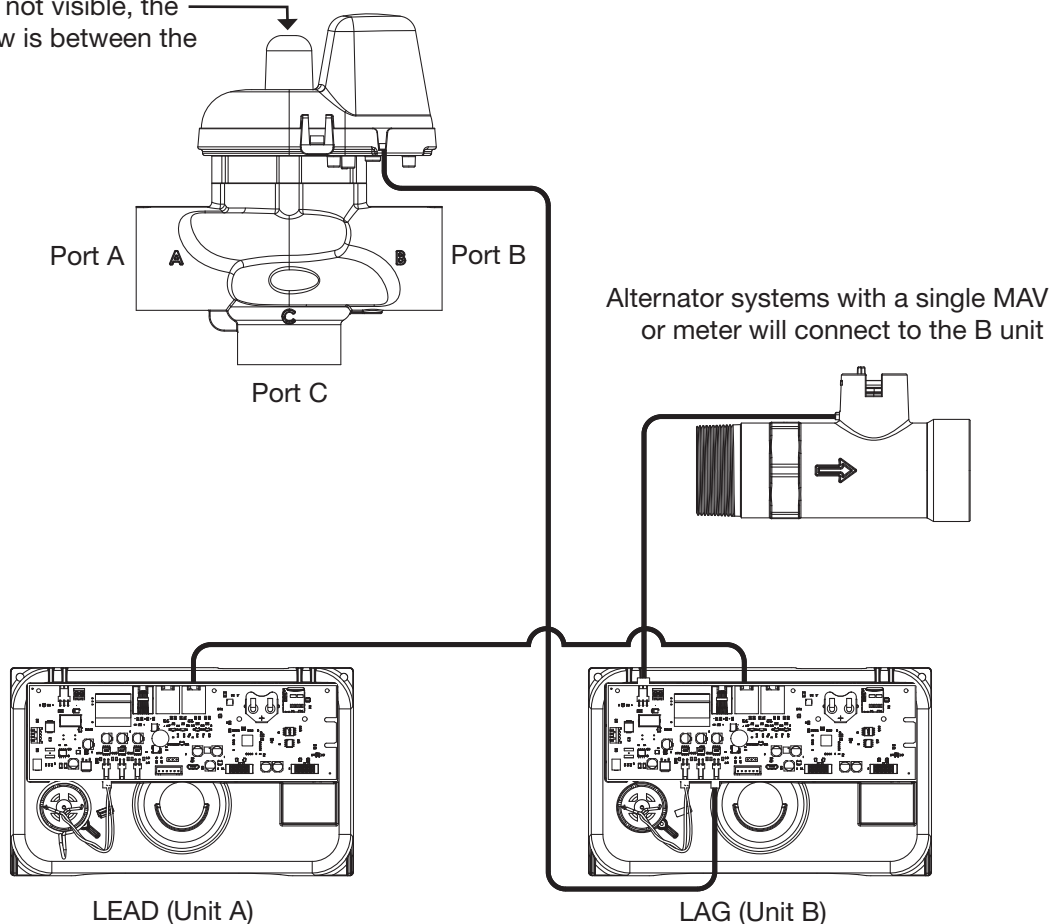

System Examples

MULTI-TANK SYSTEM, 3 UNIT SHOWN

System consists of 3 power heads, 2 communication cables and 3 No Hard Water Bypass (Isolation) valves

Electrical Connections:

- Each unit's isolation valve motor wire is connected to the 2-pin connector labeled BYPASS on each unit's PC board.
- Using two standard straight through RJ45 cables (T-568B wiring), connect the "COMM OUT" of the LEAD control to the "COMM IN" of LAG 1 and the "COMM OUT" of LAG 1 to the "COMM IN" of LAG 2 (See Page 6 for connector locations)

Plumbing Connections:

- To regenerate with raw/treated water, the isolation valve is piped into the outlet of each unit.
- To regenerate with soft/treated water, the isolation valve is piped into the inlet of each unit.

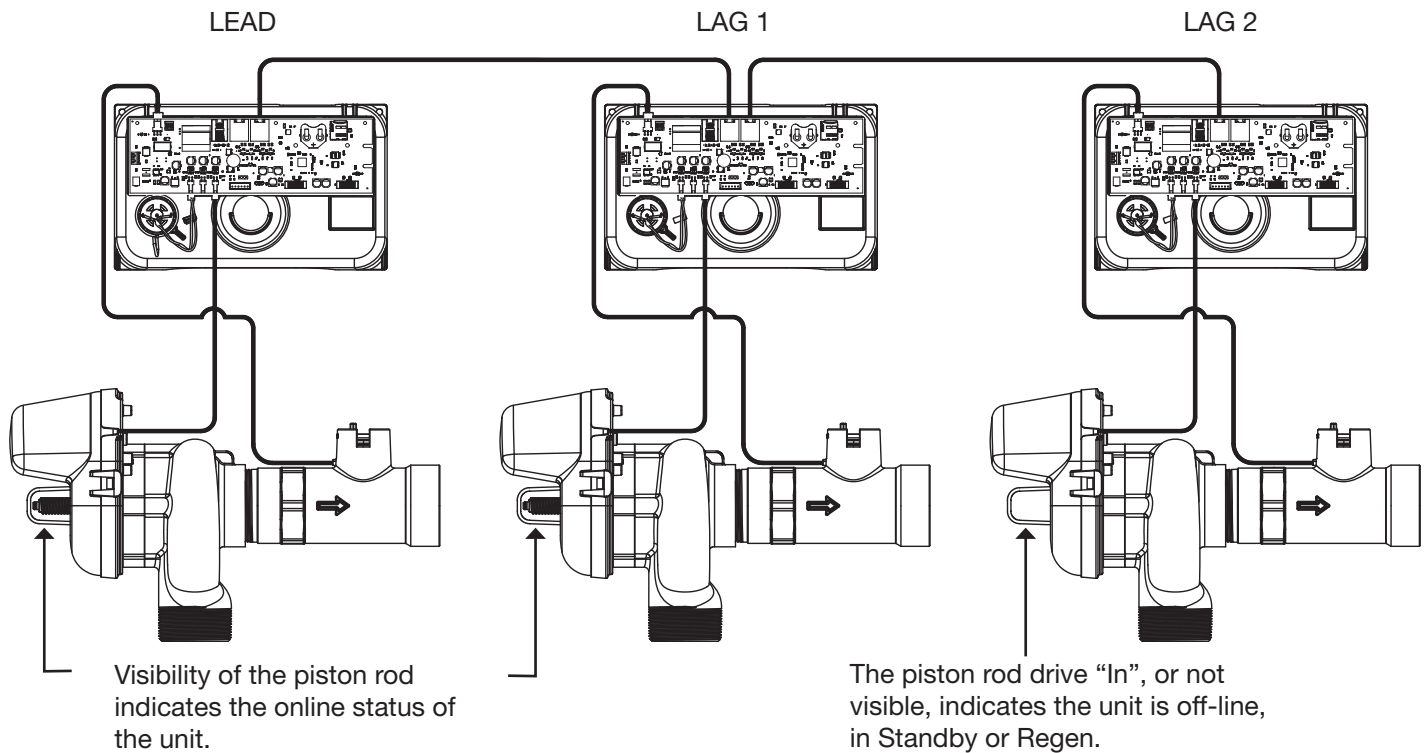

Programming

BUTTON FUNCTION AND PROGRAMMING KEY SEQUENCE

Standby LED

- Signals that a unit is not in service, or regen
- Flashes to alert status conditions
 - 1 per second indicates flow had been detected while the unit was off-line

Online LED

- Signals that a unit is currently in service

Regen LED

- Signals that a unit is currently in regen

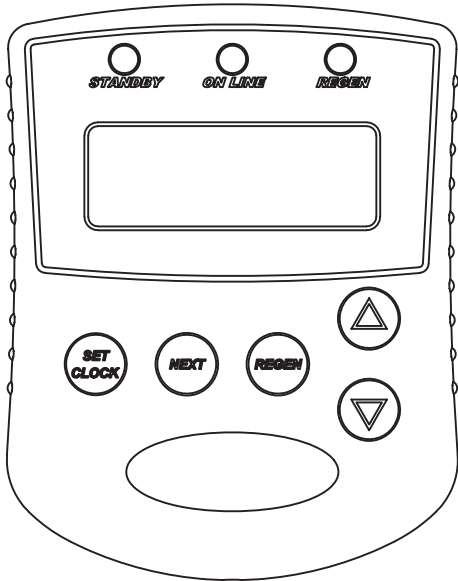

Set Clock
Set clock from User Screens
Exit & save from setup or program screens.

Next
Move to the next display

Up **Down**
Change variable being displayed

Regen
Toggles scheduled regen time on/off.
Holding for >3 sec. starts immediate regen (immediate regen is the only option if set to immediately regenerate upon 0 gallons).
Moves back one display while in program mode.

Next **Regen**
Reset
Holding for >3 seconds initiates a reset. The software version is shown and the piston returns to the "home" position, re-synchronizing the valve.

Set Clock **Regen**
History Reset
Holding the Set Clock & Regen buttons for >3 seconds initiates a totalizer or history reset.

Down **Next** **Up** **Set Clock**
Key sequence to lock and unlock programming screens

Programming Key Sequences

Programming Level	Buttons
Main Setup Menu	Next Down
Diagnostics and History	Up Down

MAIN MENU SCREEN

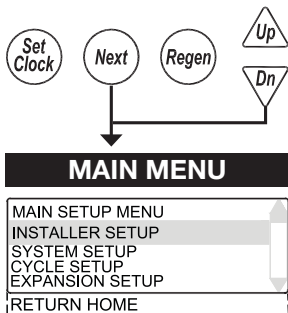

Accessed by pressing NEXT and DOWN simultaneously for >3 seconds while in one of the user screens.

INSTALLER SETUP - Setup items under the Installer Setup Screens section

SYSTEM SETUP - Setup items in the System Setup Screens section

CYCLE SETUP - Setup the primary and secondary regeneration cycles

EXPANSION SETUP - Setup expansion port options if expansion boards are installed

RETURN HOME - Return back to the user screens

- Once you are in any of the submenus, use the REGEN button to back out to the Main Menu
- The SET CLOCK button will typically exit from any menu and return to the user screens

Programming

QUICK REFERENCE

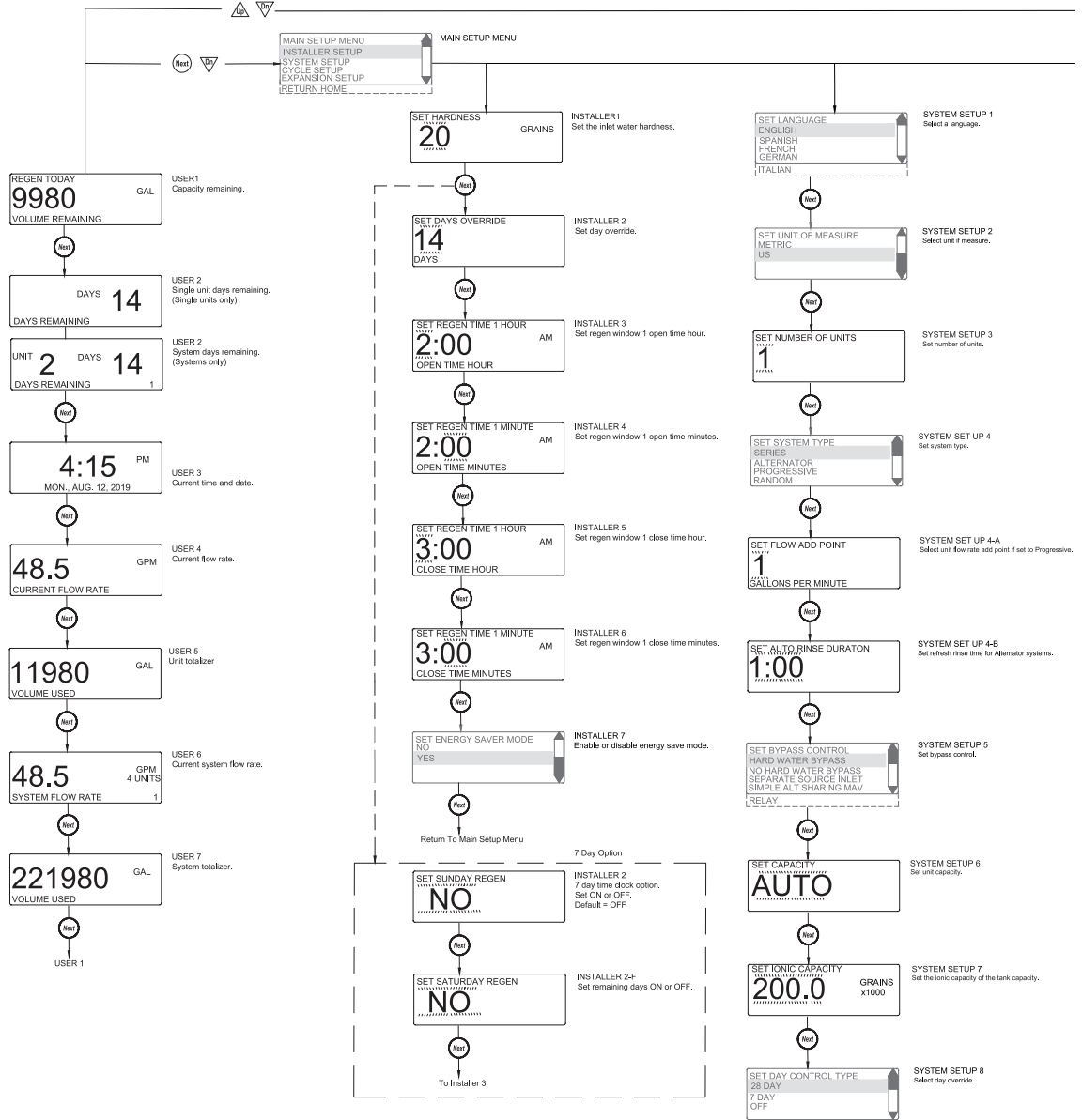

Recommended System Setup Sequence

1. Connect all wiring and communication cables.
2. Apply power.
3. Select System Setup from the Main Setup Menu.
4. Select the correct language to use in System Setup 1.
5. Select the correct unit of measurement in System Setup 2.
6. Select the correct number of units in System Setup 3.
 - a. Setting this value assigns LEAD status to that unit
 - b. The LEAD unit will establish communication with the remaining units and transfer the remaining settings to them.
7. Step through the remainder of the System Setup screens and set appropriately.
8. Select Installer Setup from the Main Setup Menu and set the installer settings appropriately.
9. Select Cycle Setup from the Main Setup Menu and set the regenerations cycles appropriately.
10. If using the relay board, select Expansion Setup from the Main Setup Menu and set the relays as needed.

WS2 Programming Screen Quick Reference

1. Individual screen descriptions and settings are detailed on the following pages.
2. Some screens have been omitted for clarity.

Programming

QUICK REFERENCE

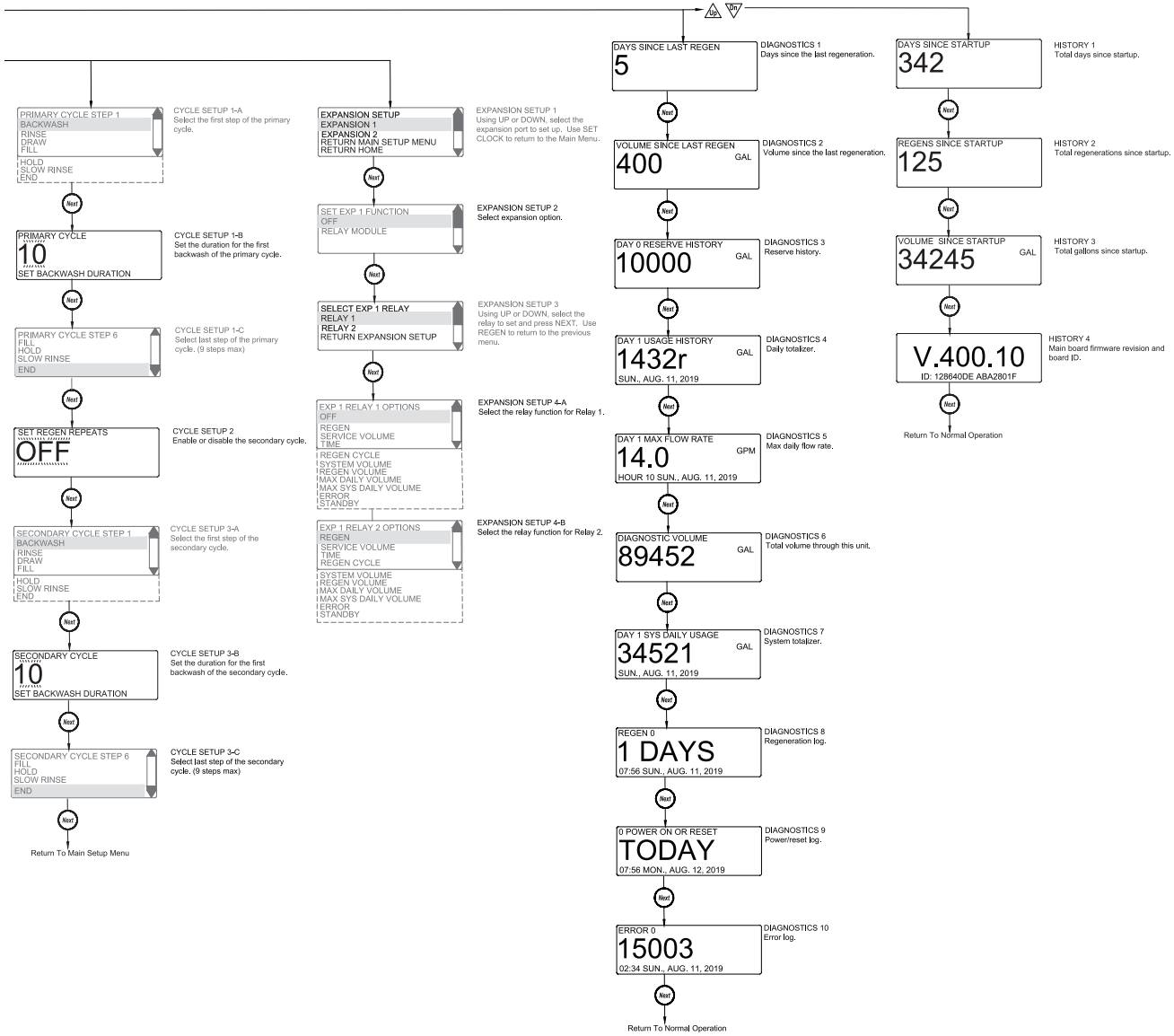

Continued from Previous Page

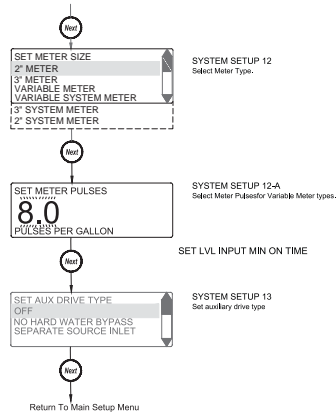

List Of Error Codes	
Code	Description
1001	No Encoder Pulses
1002	Unexpected Stall, Main Drive
1003	Run Time Too Long, Main Drive
1010	Main drive unable to unwind after stall
14001	Message Queue Full
15003	Run Time Too Long, Bypass Drive
15010	Run Time Too Short, Bypass Drive Could Not Drive Offline
15011	Run Time Too Short, Bypass Drive Could Not Drive Online
16001	Communication Lost With Unit 2
16002	Communication Lost With Unit 3
16003	Communication Lost With Unit 4
18000	Reset Performed
18001	Power Loss
18002	Power Restored
20001	Run time too long, AUX drive
20002	Run time too short during unwind, AUX drive
20011	Run time too short, AUX drive

TYPICAL USER SCREENS

USER 1

REGEN TODAY
9980 GAL
VOLUME REMAINING 1L

Set Clock Next Regen Up Dn

USER 1 - Capacity Remaining

- Displays the unit's current capacity remaining
- This screen does not display on units with volumetric capacity turned off
- Can be manually reduced by holding the down arrow
- An "L" will be displayed next to the unit number if it is considered the LEAD unit.

USER 2

DAYS **14**
DAYS REMAINING

Set Clock Next Regen Up Dn

USER 2 - Days Remaining, Single Unit

- Displays a single unit's days until a regeneration, based on the day override setting
- This screen does not display on units with day override turned off
- On systems, the LEAD unit displays the days remaining
- Days can be manually reduced by holding the down arrow

USER 2B

UNIT **2** DAYS **14**
DAYS REMAINING 1

Set Clock Next Regen Up Dn

USER 2B - Days Remaining, System

- The LEAD in a system displays the days until a regeneration, based on the day override settings.
- The displays also indicates which unit the day override is currently pertaining to
 - Series regen systems do not display a unit as they will regenerate all units sequentially

USER 3

4:15 PM
MON., AUG. 12, 2019

Set Clock Next Regen Up Dn

USER 3 - Time

- Displays the current date and time of day

USER 4

48.5 GPM
CURRENT FLOW RATE

Set Clock Next Regen Up Dn

USER 4 - Flow Rate, Unit

- Displays that unit's current flow rate

USER 5

11980 GAL
VOLUME USED

Set Clock Next Regen Up Dn

USER 5 - Volume Totalizer, Unit

- Displays the total volume since install / reset
- Resettable to zero, while in this screen, by holding the "Set Clock" & "Regen" buttons

Programming

TYPICAL USER SCREENS (CONTINUED)

USER 6

48.5 GPM
4 UNITS

SYSTEM FLOW RATE 1

Set Clock Next Regen Up Dn

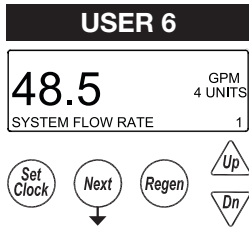

USER 6 – Flow Rate, System

- Displays the current combined flow rate of all the units in the system
- This screen does not display on single tank units or systems with volumetric capacity turned off

USER 7

221980

SYSTEM GALLONS USED 1

Set Clock Next Regen Up Dn

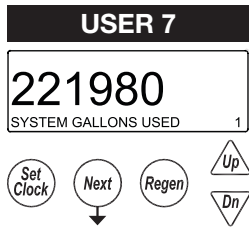

USER 7 – Volume Totalizer, System

- Displays the total volume of the system since install / reset
- Resettable to zero, while in this screen, by holding the “Set Clock” & “Regen” buttons
- This screen does not display on single tank units

TO USER 1

Programming

SETTING TIME OF DAY AND DATE

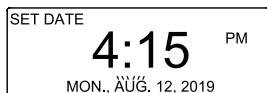
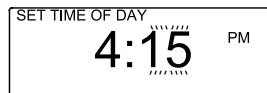
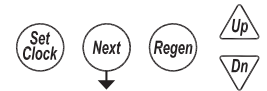
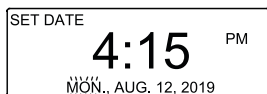
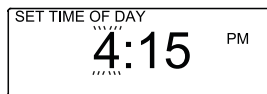

SET TIME AND DATE

Accessed by pressing Set Clock while in the User Screens. Use UP or DOWN arrows to scroll through the available settings.

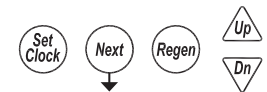
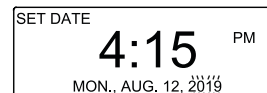
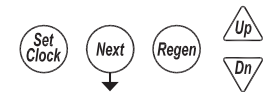
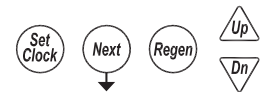
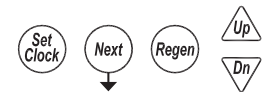

**RETURN TO
NORMAL OPERATION**

NOTIFICATIONS



• REGEN TODAY

- Flashing indicates a regeneration has been manually set and can be turned off by pressing and releasing the REGEN button
- A solid display indicates the regeneration has been scheduled by input requirements and can't be manually turned off

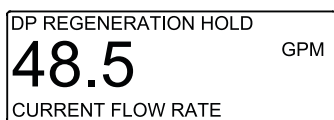

• REGENERATION HOLD / REGENERATION START

- The display will flash "DP REGENERATION HOLD" or "DP REGENERATION START", depending on settings, to indicate an external switch closure to the Aux. Input

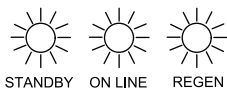

• HIGH VOLUME

- Screen flashes indicating setpoint was reached when using relay outputs to signal high water usage. All LED lights flash and the relay with that setpoint closes.
 - Screen and the relay are reset by pressing any button
 - System operates as normal behind the indicator screen.
- Only active if Timer 2 or Timer 3 is set to "Day & Gal" or "Day & Gal & System"

ERRORS

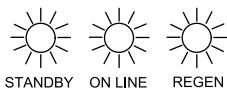

• NUMBER OF UNITS ERROR

- The LEAD unit of a system would flash an error screen alerting of a loss of communication with a unit
- Check for proper operation and connectivity of the unit specified as lost communications
- Pressing any button will return the user to the # units set up screen to correct / verify the value of units in the system. Exiting will re-establish communications
- Each unit of the system will regenerate, based on its settings, with hard water bypass

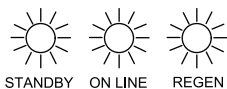

• FUNCTIONAL ERROR

- "Error" and its code will flash on the display with a red backlight
- The unit attempts to return to service but will not regenerate until the error is cleared
- See troubleshooting section for a description of possible error codes.

SYSTEM SETUP SCREENS

Accessed by pressing NEXT and DOWN simultaneously for >3 seconds and selecting SYSTEM SETUP from the Main Menu. On multi-unit systems, only program the main valve number one or the LEAD unit.

- System setup screens will be locked on units determined to be a LAG of a system
 - LAG units need to be reset, "Next" & "Regen" from any screen to have their LAG status turned off.

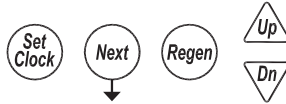
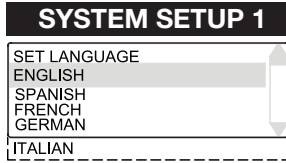

SYSTEM SETUP 1 - Select language

Select one of the available languages to be used when displaying text on the display.

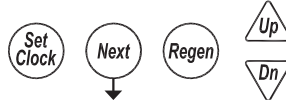
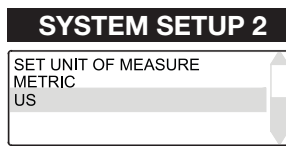

SYSTEM SETUP 2 - Set unit of measure

Select either Metric units or US units for measurements.

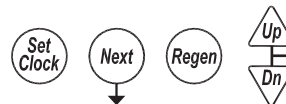
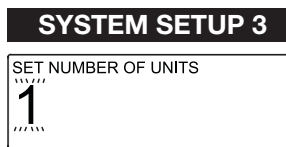

SYSTEM SETUP 3 - Set number of units

Up to 16 units can be daisy chained using the communication in and out ports on the controls.

SYSTEM SETUP 3A - Enable or disable Modbus
Enable or disable the Modbus communication protocol.

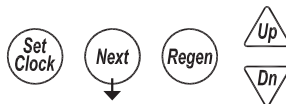
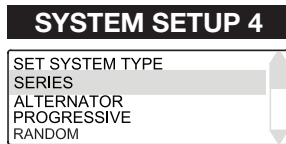
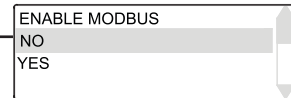

SYSTEM SETUP 4 - Select System Type / Operation

This screen is only available if the number of units selected is greater than 1.

Series: All units are always online unless they are regenerating.

- Units in a series flow system will determine the need to regenerate based on:
 - Any one unit reaching 0 capacity
 - Day override
 - Any one unit's need to regenerate will initiate sequential regenerations of all units (series regeneration).
 - Immediate systems will regenerate all units in series upon the first unit reaching 0 capacity.
 - Delayed units will regenerate during one or more of the delayed regeneration windows.
- Alternator: Operates the system as an alternator, having one unit off-line at all times either regenerating or fully regenerated.**
- A unit in an alternator system will determine the need to regenerate based on:
 - The current LEAD unit reaching 0 capacity.
 - Immediate systems immediately regenerate and alternate the exhausted unit with a fully regenerated standby unit.
 - Delayed systems will immediately alternate the exhausted unit with a fully regenerated standby unit, and regenerate at the next available time slot.
 - LEAD unit regenerates based on LAG units.
 - The first LAG unit depleting down to 15% less than its ratio of system capacity
 - 1/3 for a 4 unit; 1/2 for a 3 unit.
 - The second LAG unit depleting down to 15% less than its ratio of system capacity
 - 2/3 for a 4 unit.

Programming

SYSTEM SETUP SCREENS (CONTINUED)

- Delayed systems will flag LEAD units based on LAG capacity, but will not alternate with remaining capacity until the next available delayed time.
 - Day override
 - 1 day; 1 unit will regen
 - Day triggered regens will run at the time set for the first regeneration window
 - Progressive (Demand Recall):** one unit is always online & additional units are added as the online units exceed the flow add point.
 - Additional units are brought online when:
 - The adder point is exceeded for 30 seconds
 - All required units required to cover the flow conditions will be brought into service immediately if the flow exceeds 120% of the adder point.
 - Units will go off-line when
 - System flow reduces to 95% of the set adder point / unit for 1 minute.
 - Any unit in a demand recall system will determine the need to regenerate based on:
 - Each unit individually reaching 0 capacity
 - Immediate systems will regenerate depleted units immediately after current flow conditions allow depleted units off-line.
 - Delayed units will alternate LEAD units immediately upon exhaustion and regenerate them at the next available time slot.
 - Day Override
 - One unit will be regenerated per delayed time slot (i.e. a 4 unit system will need 4 delayed times to regenerate all units / set number of days).
 - Day triggered regens will run at the time set in the first regeneration window
 - Units cannot regenerate if flow demands them to remain online
 - Immediate units regen immediately after flow allows them off-line
 - Delayed units regen at the next available time slot
 - Day units regen at the next time slot
- Random:** All units are online. Units in this system can regenerate in any random order. Regeneration is initiated on a unit when its volume capacity reaches zero. When one unit is regenerating, any other calls for regeneration will be delayed until after current regeneration is complete.

SYSTEM SETUP 4A

SET FLOW ADD POINT
1
GALLONS PER MINUTE

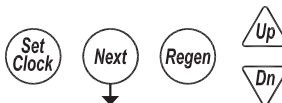

SYSTEM SETUP 4A - Set flow add point

- Only available on Progressive systems
- Sets the flow rate which controls the point at which more valves are brought online or taken off-line based on the flow rate

SYSTEM SETUP 4B

SET AUTO RINSE DURATON
1:00

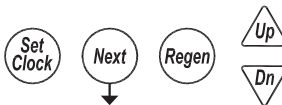

SYSTEM SETUP 4B - Set Pre-Service Rinse

- Only available on Alternator systems
- Standby units will run through a rinse cycle before coming into service

SYSTEM SETUP SCREENS (CONTINUED)

SYSTEM SETUP 5

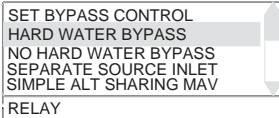

SYSTEM SETUP 5 - Select bypass control

- Selections allow enabling and timing control of motorized drive
- Selection availability can vary by the type of system
- Custom timing sequences can be configured under “Custom Auxiliary Output Drive Timing” at the end of the programming section

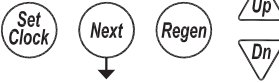

Hardwater Bypass

- Only available on single units
- Unit will internally bypass hard water to the service lines while in regeneration

No Hardwater Bypass

- Each unit has isolation to control system operation and will not supply service water during regeneration
- Drive timing will bring the unit into service during fill

Separate Source

- Each unit has isolation to control system operation and will not supply service water during regeneration
- Drive timing will keep units isolated through the entire regeneration sequence

Simple Alt Sharing MAV

- Only available when set to a 2 unit alternator
- A “Simple 2 Unit” shares one MAV to be electrically connected to the bypass connection of the “B” (LAG) unit

Relay

- Only available when when the optional relay expansion module is installed and one or both of the relays is set for Standby
- Isolation will be done through the optional relay expansion module and does not initialize the BYPASS motorized drive circuit

Simple Alt Sharing MAV

- Only available when set to a 2 unit alternator
- A “Simple 2 Unit” shares one MAV to be electrically connected to the bypass connection of the “B” (LAG) unit

SYSTEM SETUP 6



SYSTEM SETUP 6 – Set unit capacity

- Only available for US based measurements
- Allows for automatic calculation of tank capacity or user entered capacity

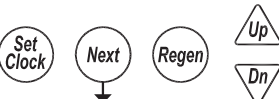

SYSTEM SETUP 7



SYSTEM SETUP 7 - Set the ionic capacity of the tank

- Only available for US based measurements
- Used for auto-calculation of unit capacity

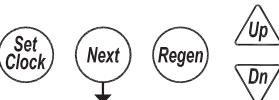

SYSTEM SETUP 8

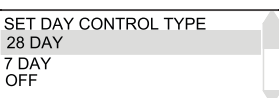

SYSTEM SETUP 8 - Day override control

- 28 day time clock: Used to regenerate units based on a set number of days between regenerations
- 7 Day Time Clock: Used to control regeneration based on specific days
- OFF: Days have no control on regenerations, and will not be a selection if volumetric capacity is set to OFF

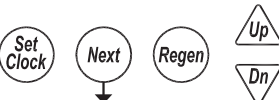

SYSTEM SETUP SCREENS (CONTINUED)

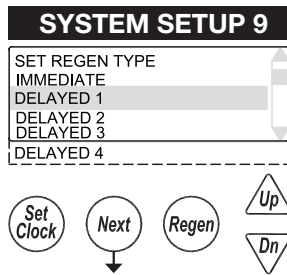

SYSTEM SETUP 9 - Regeneration control

Delayed 1 – 4

- Delays regeneration of units upon reaching 0 gallons capacity
- Allows setting of up to 4 regeneration windows per day
- Systems with delayed regen will remove a unit from service based upon 0 capacity and regenerate at the scheduled regen time.
 - Any unit needing regeneration while the window of time is available will be able to regenerate. Only one unit will regen at a time
 - Day driven regens will regen at the Delayed 1 window time
 - Depleted units will regen at the next available delayed time slot

Immediate-Immediate regeneration of units upon reaching 0 capacity

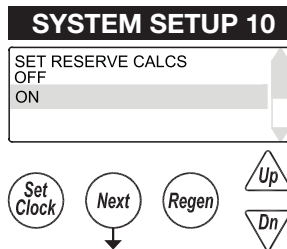

SYSTEM SETUP 10 – Automatic reserve calculation

This screen will not display on units set to Immediate, capacity set to Off, or any multi-unit systems

On: Unit will regenerate before reaching 0 capacity, based on previous usage trends

Requires delayed regeneration

OFF: Regeneration is scheduled after reaching 0 capacity

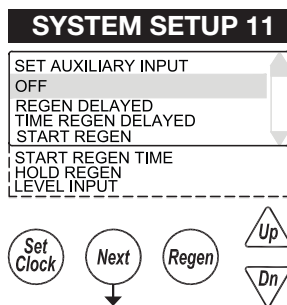

SYSTEM SETUP 11 - Auxiliary Input

OFF

- Auxiliary input is disabled

REGEN DELAYED

- Control will immediately schedule a regen upon switch closure
- Systems follow “Delayed Logic” regenerating flagged units in available time slots

TIME REGEN DELAYED

- Control will immediately schedule a regeneration upon accumulating 2 minutes of intermittent switch closures
- Systems follow “Delayed Logic” regenerating flagged units in available time slots

START REGEN

- Control will start an immediate regeneration upon switch closure
- Systems follow “Immediate logic” regenerating all flagged units sequentially

START REGEN TIME

- Control will immediately regenerate upon accumulating 2 minutes of intermittent switch
- Systems follow “Immediate logic” regenerating all flagged units sequentially

HOLD REGEN

- Regeneration will not be allowed as long as there is switch closure
 - On0 units will regenerate immediately after the hold switch opens
 - Delayed regenerations will be delayed until the next scheduled time if the hold is active when the scheduled time passes

LEVEL INPUT

- Only available on single units
- External switching can be used to control the Online/Standby status
 - Switch closure will trigger the unit to go to a standby condition

Programming

SYSTEM SETUP SCREENS (CONTINUED)

SYSTEM SETUP 11A

SET LVL INPUT MIN ON TIME
30
(mm:ss)

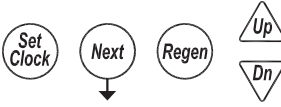

SYSTEM SETUP 11A - Level Input option selected

Set a time duration of switch closure when Level Input option is selected

SYSTEM SETUP 12

SET METER SIZE
2" METER
3" METER
VARIABLE METER
VARIABLE SYSTEM METER
3" SYSTEM METER
2" SYSTEM METER

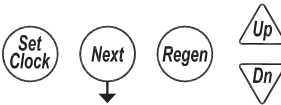

SYSTEM SETUP 12 - Meter Size Selection

2" METER: Setting for using a factory 2" meter

3" METER: Setting for using a factory 3" meter

VARIABLE METER: Used to set meter input off custom pulse rate, typically for non-factory meters

VARIABLE SYSTEM METER: Only available on 2 unit alternators. The system shares 1 external meter which is connected to the LAG unit's meter connection.

3" SYSTEM METER: Only available on 2 unit alternators. The system shares 1 external meter which is connected to the LAG unit's meter connection.

2" SYSTEM METER: Only available on 2 unit alternators. The system shares 1 external meter which is connected to the LAG unit's meter connection.

SYSTEM SETUP 12A

SET METER PULSES
8.0
PULSES PER GALLON

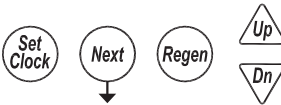

SYSTEM SETUP 12A - Set Meter Pulses / Gallon

-Only displays if "VARIABLE METER" or "VARIABLE SYSTEM METER" is selected in the previous screen

-Set to the desired pulse rate of the installed metering device

SYSTEM SETUP 13

SET AUX DRIVE TYPE
OFF
NO HARD WATER BYPASS
SEPARATE SOURCE INLET

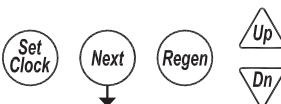

SYSTEM SETUP 13- Auxiliary Drive

- Selections allow enabling and timing control of the Auxiliary motorized drive circuit
- Requires a factory motorized drive to be connected to the AUX DRIVE connector
- Custom timing sequences can be configured under "Custom Auxiliary Output Drive Timing" at the end of the programming section

Off

- The auxiliary drive output is disabled

No Hard Water Bypass

- Each unit has isolation to control system operation and will not supply service water during regeneration
- Drive timing will bring the unit into service during fill

Separate Source

- Each unit has isolation to control system operation and will not supply service water during regeneration
- Drive timing will keep units isolated through the entire regeneration sequence

Programming

CYCLE SETUP SCREENS

Accessed by pressing NEXT and DOWN simultaneously for >3 seconds and selecting CYCLE SETUP from the Main Menu.

CYCLE SETUP 1A

SET CYCLE 1 STEP 1
BACKWASH
RINSE
DRAW
FILL
HOLD
SLOW RINSE
END

CYCLE SETUP 1A

Select first step of the primary regeneration cycle.

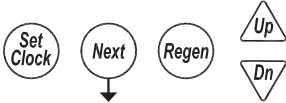

CYCLE SETUP 1B

PRIMARY CYCLE
10
SET BACKWASH DURATION

CYCLE SETUP 1B

Select the time of duration for the first step of the primary regeneration cycle.

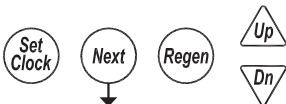

CYCLE SETUP 1C

PRIMARY CYCLE STEP 6
FILL
HOLD
SLOW RINSE
END

CYCLE SETUP 1C

Select the second step of the primary regeneration cycle.

Continue selecting the step type and entering the duration until the primary regeneration cycle has been defined.

Select END as the last step of the primary regeneration cycle.

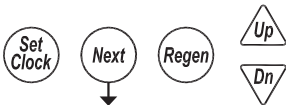

CYCLE SETUP 2

SET REGEN REPEATS
OFF

CYCLE SETUP 2

Select regeneration repeats, 1-9 or OFF.

Repeats the primary regeneration cycle a selected number of times before regenerating a single time with the secondary regeneration cycle.

The following screens will not appear if regeneration repeats is set to OFF.



CYCLE SETUP 3A

SET CYCLE 2 STEP 1
BACKWASH
RINSE
DRAW
FILL
HOLD
SLOW RINSE
END

CYCLE SETUP 3A

Select first step of the secondary regeneration cycle.

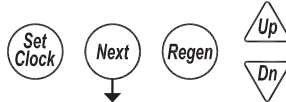

CYCLE SETUP 3B

SET CYCLE 2 DURATION
10
SET BACKWASH DURATION

CYCLE SETUP 3B

Select the time of duration for the first step of the secondary regeneration cycle.

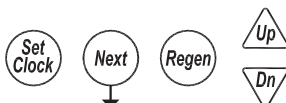

CYCLE SETUP SCREENS (CONTINUED)

CYCLE SETUP 3C CYCLE SETUP 3C

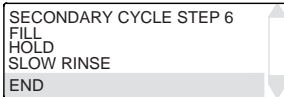

SECONDARY CYCLE STEP 6
FILL
HOLD
SLOW RINSE
END

Select the second step of the secondary regeneration cycle.

Continue selecting the step type and entering the duration until the secondary regeneration cycle has been defined.

Select END as the last step of the secondary regeneration cycle.

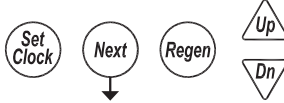

**RETURN TO MAIN
MENU**

EXPANSION SETUP SCREENS

Accessed by pressing NEXT and DOWN simultaneously for >3 seconds and selecting EXPANSION SETUP from the Main Menu.

EXPANSION SETUP 1

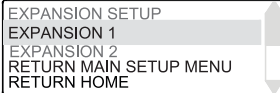

EXPANSION SETUP
EXPANSION 1
EXPANSION 2
RETURN MAIN SETUP MENU
RETURN HOME

EXPANSION SETUP 1

Select the expansion port, 1 or 2, that you will modify.

EXPANSION SETUP 2

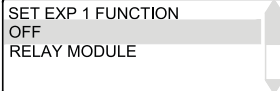

SET EXP 1 FUNCTION
OFF
RELAY MODULE

EXPANSION SETUP 2

Select the installed expansion board or OFF if no expansion board is installed.

EXPANSION SETUP 2A

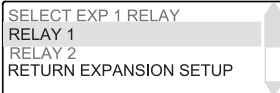

SELECT EXP 1 RELAY
RELAY 1
RELAY 2
RETURN EXPANSION SETUP

EXPANSION SETUP 2A

If RELAY MODULE was selected from Expansion Setup 2, select which relay to modify.

EXPANSION SETUP 2B

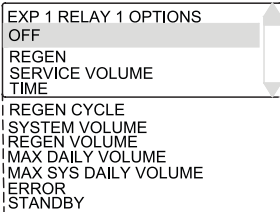

EXP 1 RELAY 1 OPTIONS
OFF
REGEN
SERVICE VOLUME
TIME
REGEN CYCLE
SYSTEM VOLUME
REGEN VOLUME
MAX DAILY VOLUME
MAX SYS DAILY VOLUME
ERROR
STANDBY

EXPANSION SETUP 2B

Select how the relay should function or OFF if the relay will not be used.

OFF - Relay is not used

REGEN - The relay is energized while the control is regenerating

SERVICE VOLUME - The relay is energized, during service only, every specified amount of volume used and for a specified amount of time

TIME - The relay is energized based on a set amount of time after the start of regeneration and will stay energized for a specified amount of time

REGEN CYCLE - The relay is energized based on the start of a specified cycle and will stay energized for a specified amount of time

SYSTEM VOLUME - The relay is energized, at a specified volume, based on combined volume usage of all units in the system and stays energized for a specified time. Only available on the LEAD unit of a system.

REGEN VOLUME - The relay is energized, during service & while in regen, every specified amount of service flow and for a specified amount of time

MAX DAILY VOLUME - The relay is energized, based on a units usage, at a specified daily volume to signal a usage alarm. "HIGH VOLUME ERROR" flashes on the screen while unit continues to operate as normal. Pressing any button resets the relay and returns the unit to the user screens.

MAX SYS DAILY VOLUME - The relay is energized, at a specified amount, based on combined volume usage of all units in the system. "HIGH VOLUME ERROR" flashes on the screen while unit continues to operate as normal. Pressing any button resets the relay and returns the unit to the user screens. Only available on the LEAD unit of a system

ERROR - The relay is energized to signal an error condition

STANDBY - The relay is energized based on the unit's Standby status. Relays could be used to control external valving or signaling a unit's Online status.

Programming

EXPANSION SETUP SCREENS (CONTINUED)

EXPANSION SETUP 2B-1A

SET EXP 1 RLY 1 VOLUME
20 GAL
SERVICE VOLUME

EXPANSION SETUP 2B-1A SERVICE VOLUME

- Enter the volume at which the relay should energize

EXPANSION SETUP 2B-1B

SET EXP 1 RLY 1 ON TIME
3:00
RELAY ON TIME

EXPANSION SETUP 2B-1B SERVICE VOLUME

- Enter the total time to keep the relay energized

EXPANSION SETUP 2B-2A

SET EXP 1 RLY 1 DLY TIME
10:00
RELAY START DELAY

EXPANSION SETUP 2B-2A TIME

- Enter the delay time, after regeneration starts, before energizing the relay

EXPANSION SETUP 2B-2B

SET EXP 1 RLY 1 ON TIME
3:00
RELAY ON TIME

EXPANSION SETUP 2B-2B TIME

- Enter the total time to keep the relay energized

EXPANSION SETUP 2B-3A

SET RELAY 1 CYCLE
BACKWASH
RINSE
DRAW
FILL
HOLD
SLOW RINSE

EXPANSION SETUP 2B-3A REGEN CYCLE

- Select the regeneration cycle to energize the relay

EXPANSION SETUP 2B-3B

SET EXP 1 RLY 1 ON TIME
3:00
RELAY ON TIME

EXPANSION SETUP 2B-3B REGEN CYCLE

- Enter the total time to keep the relay energized

EXPANSION SETUP 2B-4A

SET EXP 1 RLY 1 VOLUME
20 GAL
SYSTEM VOLUME

EXPANSION SETUP 2B-4A SYSTEM VOLUME

- Enter the volume at which the relay should energize

EXPANSION SETUP 2B-4B

SET EXP 1 RLY 1 ON TIME
3:00
RELAY ON TIME

EXPANSION SETUP 2B-4B SYSTEM VOLUME

- Enter the total time to keep the relay energized

Programming

EXPANSION SETUP SCREENS (CONTINUED)

EXPANSION SETUP 2B-5A

SET EXP 1 RLY 1 VOLUME
20 GAL
REGEN VOLUME

EXPANSION SETUP 2B-5A REGEN VOLUME

- Enter the volume at which the relay should energize

EXPANSION SETUP 2B-5B

SET EXP 1 RLY 1 ON TIME
3:00
RELAY ON TIME

EXPANSION SETUP 2B-5B REGEN VOLUME

- Enter the total time to keep the relay energized

EXPANSION SETUP 2B-6A

SET EXP 1 RLY 1 VOLUME
20 GAL
MAX DAILY VOLUME

EXPANSION SETUP 2B-6A MAX DAILY VOLUME

- Enter the volume at which the relay should energize

EXPANSION SETUP 2B-7A

SET EXP 1 RLY 1 VOLUME
20 GAL
MAX SYS DAILY VOLUME

EXPANSION SETUP 2B-7A MAX SYS DAILY VOLUME

- Enter the volume at which the relay should energize

Programming

INSTALLER SETUP SCREENS

Accessed by pressing NEXT and DOWN simultaneously for >3 seconds and selecting INSTALLER SETUP from the Main Menu.

INSTALLER 1

SET HARDNESS
20 GRAINS

INSTALLER 1 – Set hardness

Set the inlet water hardness, in grains.

- This screen is only available if set to US units of measurement.
- This screen only available if System Setup 6 is set to AUTO.

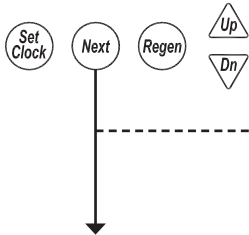

Set current day and regen days when set as a 7 day time clock in System Setup 8. See next page.

INSTALLER 2

SET DAYS OVERRIDE
14 DAYS

INSTALLER 2 – Set Days Between Regenerations (Day override)

Set day override. 1-28 days between regenerations, or if set to 7 day time clock, see 7 day setup on next page. OFF will only be displayed if “OFF” is selected in System Setup 8.

- Settings will be based on the type of day override control set in system setup.
- Off will be displayed for units with day override turned off

1 – 28: When set as a 28 day override

- Set the days between regens

1 – 7: When set as a 7 day timeclock

- Turn regen on or off for each specific day of the week, Sunday - Saturday

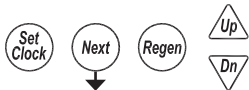

INSTALLER 3

SET REGEN TIME 1 HOUR
2:00 AM
OPEN TIME HOUR

INSTALLER 3 – Set Delayed Regeneration Open Time Hour

• A maximum of 4 regeneration windows can be set up. Set up the open time (hour:minute) and close time (hour:minute) for each window.

- Set the delayed time of regeneration, hour (AM / PM toggles at midnight)

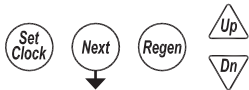

INSTALLER 4

SET REGEN TIME 1 MINUTE
2:00 AM
OPEN TIME MINUTES

INSTALLER 4 – Set Delayed Regeneration Open Time Minute

- Set delayed time of regeneration, minute

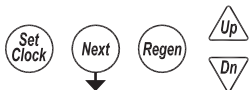

INSTALLER 5

SET REGEN TIME 1 HOUR
3:00 AM
CLOSE TIME HOUR

INSTALLER 5 – Set Delayed Regeneration Close Time Hour

- Set the delayed time of regeneration, hour (AM / PM toggles at midnight)

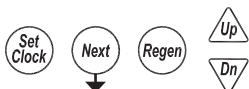

INSTALLER SETUP SCREENS (CONTINUED)

INSTALLER 6

SET REGEN TIME 1 MINUTE
3:00 AM
CLOSE TIME MINUTES

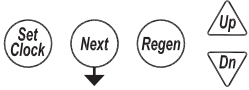

INSTALLER 6 – Set Delayed Regeneration Close Time Minute

- Set delayed time of regeneration, minute
- When configured for multiple delayed regeneration windows, repeat Installer steps 3 through 6 for each additional window

INSTALLER 7

SET ENERGY SAVER MODE
NO
YES

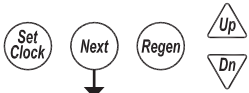

INSTALLER 7 – Set Energy Saver Mode

- When enabled, the backlight will turn off after five minutes of no flow and no button presses

RETURN TO NORMAL OPERATION

7 DAY OPTION

INSTALLER 2A

SET SUNDAY REGEN
NO

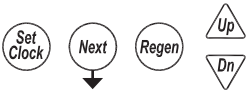

INSTALLER 2A

- Use UP or DOWN to toggle between YES or NO to control regeneration for each day
- Press NEXT to advance to the next day
- Repeat for each day of the week (e.g., no regeneration on Sunday)

INSTALLER 2B

SET SATURDAY REGEN
NO

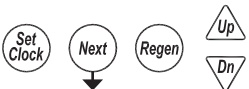

INSTALLER 2B

- Use UP or DOWN to toggle between YES or NO (e.g., regeneration on Saturday)

INSTALLER 3
(see previous page)

Programming

DIAGNOSTIC SCREENS

Note: All time stamps on the diagnostic screens are displayed in 24-hour format.

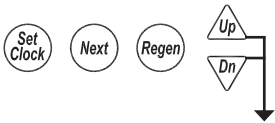

Accessed by pressing **UP** and **DOWN** simultaneously for >3 seconds.

DIAGNOSTIC 1

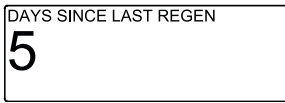

DIAGNOSTIC 1

Days since the last regeneration.

All Diagnostic History screens are resettable with the History Reset sequence while in the Diagnostics 1 screen. Holding the Set Clock and Regen buttons for > 3 seconds initiates a totalizer or history reset.

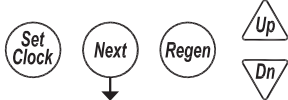

DIAGNOSTIC 2



DIAGNOSTIC 2

Volume since the last regeneration.

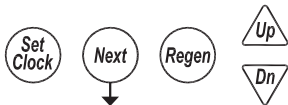

DIAGNOSTIC 3



DIAGNOSTIC 3

- Displays the reserve history
- Does not display on systems or units with reserve set to OFF
- Use the UP & DN arrows to scroll through each day's history
 - Day 0 is today's reserve (tomorrow's anticipated usage)
 - 1 was yesterday's reserve (today's anticipated usage)

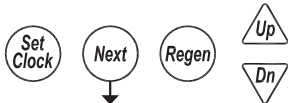

DIAGNOSTIC 4



DIAGNOSTIC 4

History of volume used.

Use UP and DOWN arrows to select a day.

0 = Today

1 = Yesterday

127 = 127 days ago (max.)

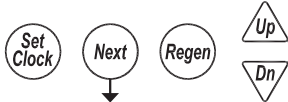

**Simultaneously
press UP and
DOWN.**

An "r" will be displayed after the volume amount if a regeneration occurred that day.

**GO TO
DIAGNOSTIC 5**

**GO TO
DIAGNOSTIC 4A**

DIAGNOSTIC SCREENS (CONTINUED)

DIAGNOSTIC 4A

DIAGNOSTIC 4A

Hourly history of volume use. Use the UP and DOWN arrow to select the hours of the day.

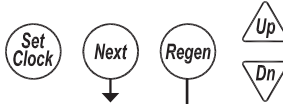

Returns user back to USE Day 0 in Diagnostic 4 screen.

DIAGNOSTIC 5

DIAGNOSTIC 5

- Displays the max flow rate and the hour it occurred
- Use the UP & DN arrows to scroll through 128 days history
 - Day 0 is today
 - Day 1 was yesterday

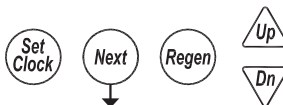
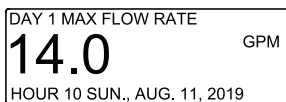

GO TO
DIAGNOSTIC 6

Simultaneously
press UP and
DOWN.

DIAGNOSTIC 5A

DIAGNOSTIC 5A

Hourly history of maximum flow rate. Use the UP and DOWN arrows to select the hours of the day from screen 5.

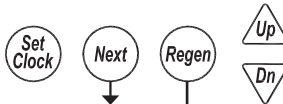
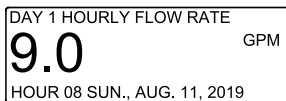

Returns user back to USE Day 0 in Diagnostic 5 screen.

DIAGNOSTIC 6

DIAGNOSTIC 6

Total volume through the unit.

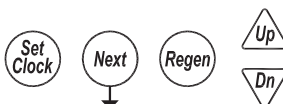

DIAGNOSTIC 7

DIAGNOSTIC 7

Total system history of volume used. Use UP and DOWN arrows to select a day.

- 0 = Today
- 1 = Yesterday
- 127 = 127 days ago (max.)

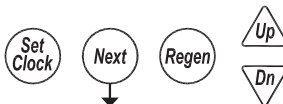
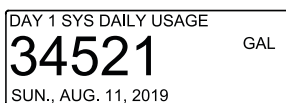

GO TO
DIAGNOSTIC 8

Simultaneously
press UP and
DOWN.

GO TO
DIAGNOSTIC 7A

DIAGNOSTIC SCREENS (CONTINUED)

DIAGNOSTIC 7A

DAY 1 SYS HOURLY USAGE
1340 GAL
HOUR 02 SUN., AUG. 11, 2019

DIAGNOSTIC 7A

Total system hourly history of volume. Use UP and DOWN arrows to select the hours of the day from Screen 7.

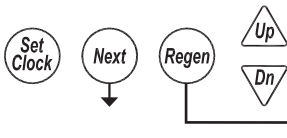

Returns user back to USE Day 0 in Diagnostic 7 screen.

DIAGNOSTIC 8

REGEN 0
1 DAYS
07:56 SUN., AUG. 11, 2019

DIAGNOSTIC 8

- Displays the time and day of the last 40 regenerations
- Use the UP and DOWN arrows to scroll through each saved regeneration

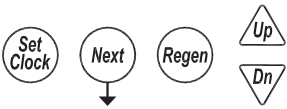

DIAGNOSTIC 9

0 POWER ON OR RESET
TODAY
07:56 MON., AUG. 12, 2019

DIAGNOSTIC 9

- Displays the time and day of the last 20 power-up/resets
- Use the UP and DOWN arrows to scroll through each saved power-up/reset

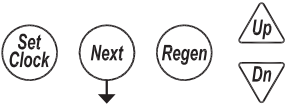

DIAGNOSTIC 10

ERROR 0
15003
02:34 SUN., AUG. 11, 2019

DIAGNOSTIC 10

- Displays the time and day of the last 20 errors
- Use the UP and DOWN arrows to scroll through each saved error

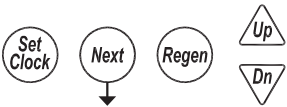

**RETURN TO USER
SCREEN**

Programming

VALVE HISTORY

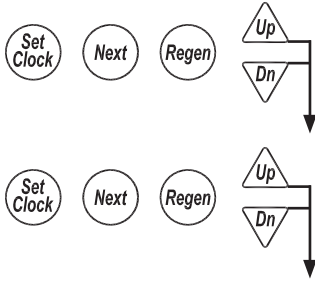

Accessed by pressing UP and DOWN simultaneously for >3 seconds, then by pressing UP and DOWN simultaneously again for >3 seconds. Non-Resettable

HISTORY 1



HISTORY 1

Total days since startup. Time only accumulates while the unit is plugged in.

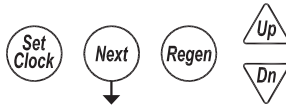

HISTORY 2

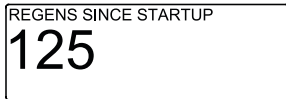

HISTORY 2

Total regenerations since startup.

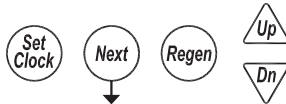

HISTORY 3



HISTORY 3

Total volume treated since startup.

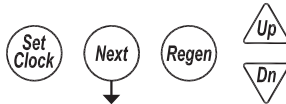

HISTORY 4



HISTORY 4

Main board software

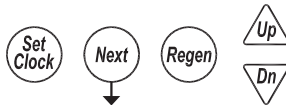

RETURN TO NORMAL OPERATION

CUSTOM AUXILIARY OUTPUT DRIVE TIMING

- Used to alter the standard timing sequence of the motorized isolation valve for complete custom timing of the drive circuits
 - Separate settings exist for System Setup 5 and System Setup 13. Setup procedure applies to both.
- Customization needs to be done after defining the regeneration cycle sequence

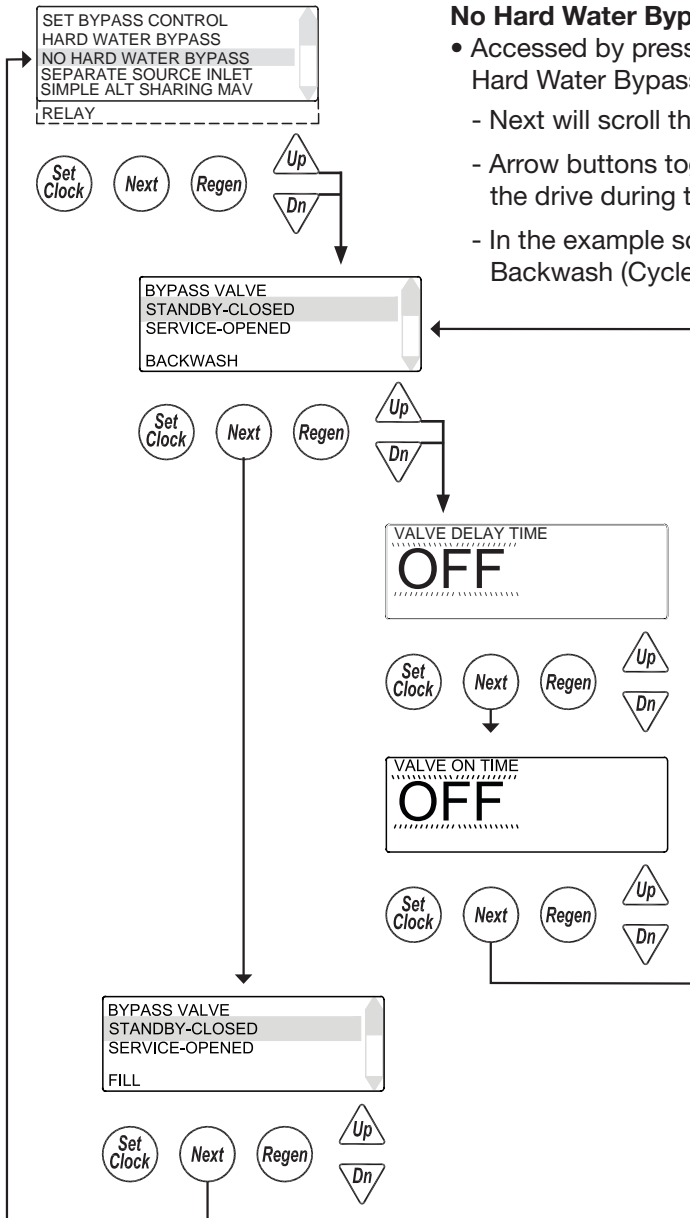

No Hard Water Bypass

- Accessed by pressing the UP and DOWN arrows simultaneously while in the No Hard Water Bypass selection in System Setup 5
 - Next will scroll through each cycle of the regeneration program
 - Arrow buttons toggle Standby and Online indicating the desired position of the drive during that cycle of the regeneration.
 - In the example screens, the “Bypass” drive will be transitioning off-line for Backwash (Cycle 1) and coming online for Fill (Cycle 5).

- Timing can be further customized per cycle by adding a time delay to the sequence.
 - Accessed by pressing the UP and DOWN arrows simultaneously while in the drive sequence screens.
 - Setting a “Start Time” delays the start of that transition after reaching set cycle*.
 - A second time screen then sets the time the drive maintains that set position before transitioning back to its previous position.
 - “Regen” will be illuminated to identify that a sequence has a time modifier associated with it.
- * (Range: 1 second - full length of regeneration cycle, being customized).

CUSTOM AUXILIARY OUTPUT DRIVE TIMING (CONTINUED)

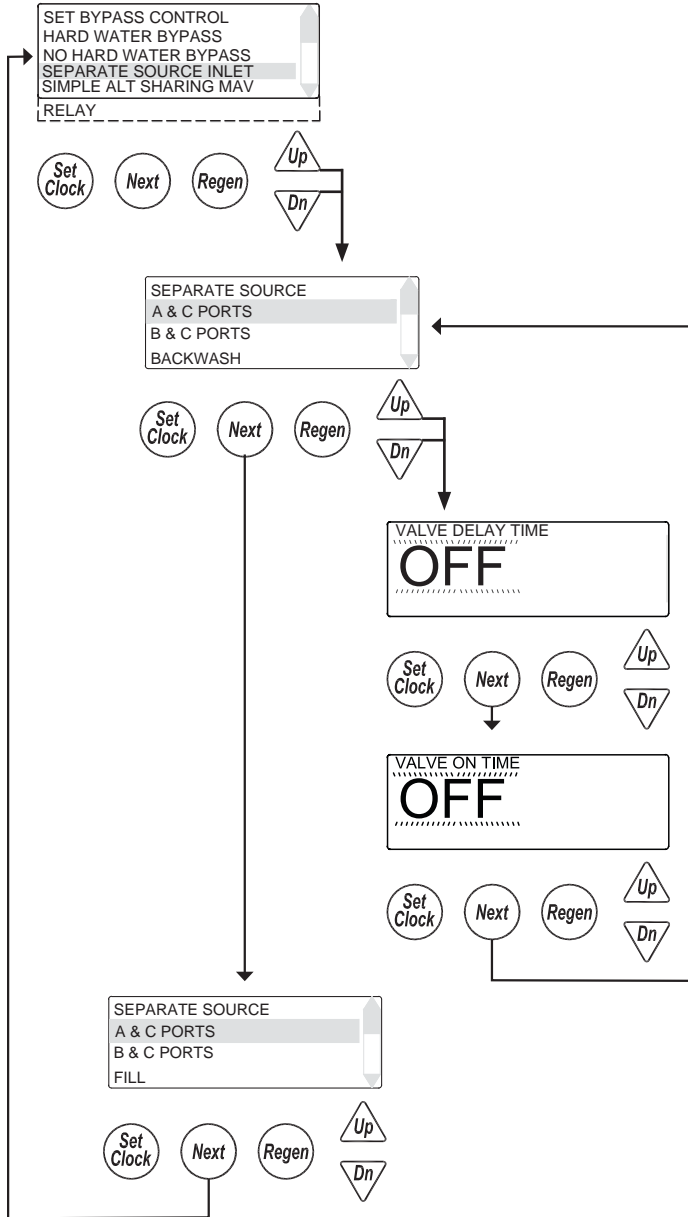

Separate Source Inlet

- Accessed by pressing the UP and DOWN arrows simultaneously while in the Separate Source Inlet selection in System Setup 5.
 - Next will scroll through each cycle of the regeneration program.
 - Arrow buttons toggle Standby and Online indicating the desired position of the drive during that cycle of the regeneration.
- Timing can be further customized per cycle by adding a time delay to the sequence.
 - Accessed by pressing the UP and DOWN arrows simultaneously while in the drive sequence screens.
 - Setting a “Start Time” delays the start of that transition after reaching set cycle.
 - A second time screen then sets the time the drive maintains that set position before transitioning back to its previous position.
 - “Regen” will be illuminated to identify that a sequence has a time modifier associated with it.

Programming

MODBUS INFORMATION

The WS2H, WS2HF, and WS3 can use Modbus through a half-duplex RS485 connection using the COMM IN connector on the first control in a system. The baud rate is adjustable from 9600 to 115200 (default). Make sure the client side is set to 8 data bits, 1 stop bit and no parity.

To enable Modbus, select System Setup 3 (Set Number of Units) and hold the UP and DOWN arrows for >3 seconds. Once the screen appears for enabling Modbus, select "Yes" from the menu and press NEXT. Select the desired baud rate and press NEXT. Set the address of the device (0 – 247) and press NEXT.

Standard T568B Cable

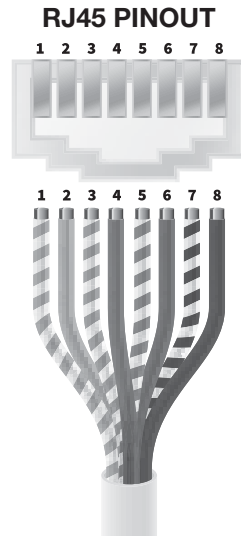

1	White/Orange
2	Orange
3	White/Green
4	Blue
5	White/Blue
6	Green
7	White/Brown
8	Brown

For wiring to a RS485 connection on a PLC

- RJ45 connector is plugged into the Incoming (Modbus) port of Unit 1
- WHT/ORG and WHT/GRN both connect to PLC DATA+
- ORG and GRN both connect to PLC DATA-
- BRN and WHT/BLU to PLC GND if needed

Wiring for USB to RS485 Adapter ULinx 485USBTB-4W

Pin	Function	T-568B Cable Colors
1	TDA(-)	GRN
2	TDB(+)	WHT/GRN
3	RDA(-)	ORG
4	RDB(+)	WHT/ORG
5	GND	BRN and WHT/BLU

Programming

MODBUS INFORMATION (CONTINUED)

Modbus Register	Description	Valid Values	Properties
40001	Year	0-99	R/W
40002	Month	1-12	R./W
40003	Day	1-31	R/W
40004	Day of Week	0-6	R/W
40005	Hour (24 Hour Format)	0-23	R/W
40006	Minute	0-59	R/W
40007	Seconds	0-59	R/W
40008	Reserved for future use		R
40009	System flow rate x 10 (GPM or LPM)		R
40010	System Total High Word (GAL or L)		R
40011	System Total Low Word (GAL or L)		R
40012	Regen Unit	1-16	R/W
40013	Valve 1 Flow Rate		R
40014	Valve 1 Capacity Remaining High Word (GAL or L)		R
40015	Valve 1 Capacity Remaining Low Word (GAL or L)		R
40016	Valve 1 Total Usage High Word (GAL or L)		R
40017	Valve 1 Total Usage Low Word (GAL or L)		R
40018	Valve 1 Flags High Word (GAL or L)		R
40019	Valve 1 Flags Low Word (GAL or L)		R
40020	Valve 1 Error Value		R
	Registers for Valves 2 through 15 contain the same information as Valve 1 and repeat. For example, register 40021 is Valve 2 Flow Rate, register 40029 is Valve 3 Flow Rate and so on.		
40133	Valve 16 Flow Rate		R
40134	Valve 16 Capacity Remaining High Word (GAL or L)		R
40135	Valve 16 Capacity Remaining Low Word (GAL or L)		R
40136	Valve 16 Total Usage High Word (GAL or L)		R
40137	Valve 16 Total Usage Low Word (GAL or L)		R
40138	Valve 16 Flags High Word (GAL or L)		R
40139	Valve 16 Flags Low Word (GAL or L)		R
40140	Valve 16 Error Value		R
40141	Next Regen Unit (upper byte) and Days Remaining (lower byte)		R
40142	Valve 1 Status	0-Not Connected 1-Service 2-Service Fill 3-Regen Fill 4-Regen 5-Regen Rinse 6-Error 7-Standby	R
40143	Valve 2 Status		R
40144	Valve 3 Status		R
40145	Valve 4 Status		R
40146	Valve 5 Status		R
40147	Valve 6 Status		R
40148	Valve 7 Status		R
40149	Valve 8 Status		R
40150	Valve 9 Status		R
40151	Valve 10 Status		R
40152	Valve 11 Status		R
40153	Valve 12 Status		R
40154	Valve 13 Status		R
40155	Valve 14 Status		R
40156	Valve 15 Status		R
40157	Valve 16 Status		R

MODBUS INFORMATION (CONTINUED)

Next Regen Unit (upper byte) and Days Remaining (lower byte)

A decimal value of 270 in hexadecimal is 0x010E. Broken down, 0x01 is valve 1 and 0x0E is 14 days. For valve 6, 14 days (0x060E) a decimal value of 1550 will be read.

Combining High and Low Words into a Single Value

Modbus registers can only hold 2 bytes worth of data, but some of the values stored in the WS2H/3 control are 4 bytes long. To get those values into Modbus registers they need to be broken down into two 2-byte values.

Start with a value of 1,234,567. In hexadecimal this is represented as 0x0012D687 (4 bytes – 00 12 D6 87). That 4-byte value is broken into 0x0012 (high word) and 0xD687 (low word). Most Modbus apps that are used can take each of those values and combine them back into the 4-byte value that is started out at.

Installation

WS2H

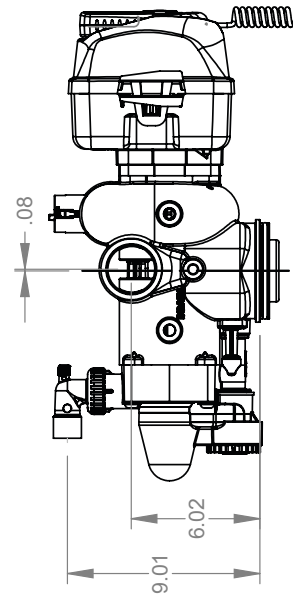
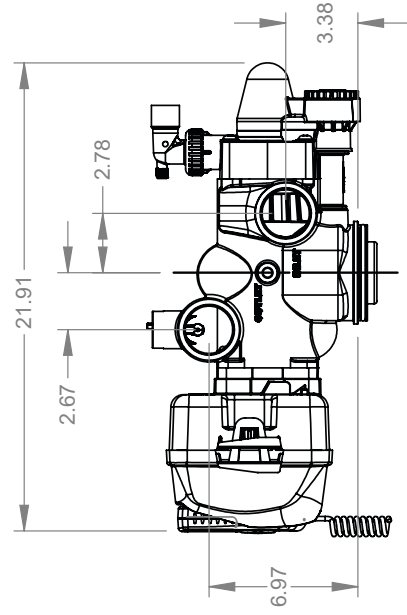
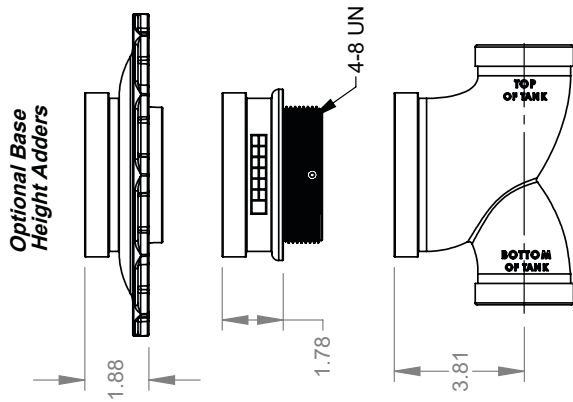
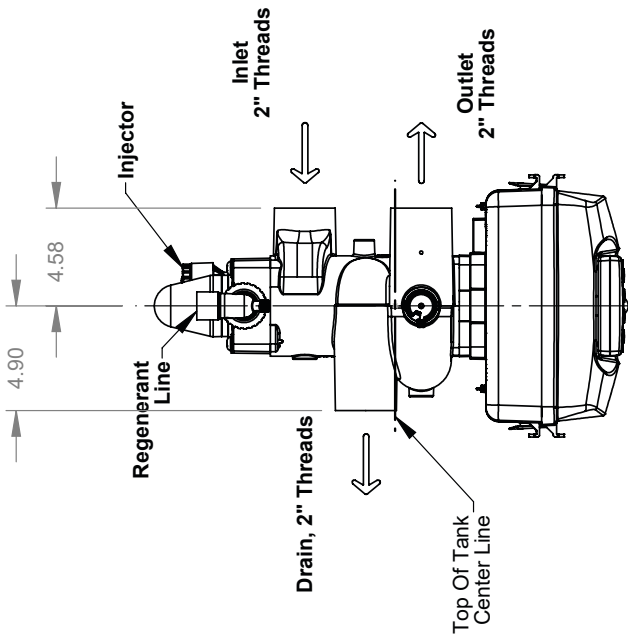

Installation

WS2HF

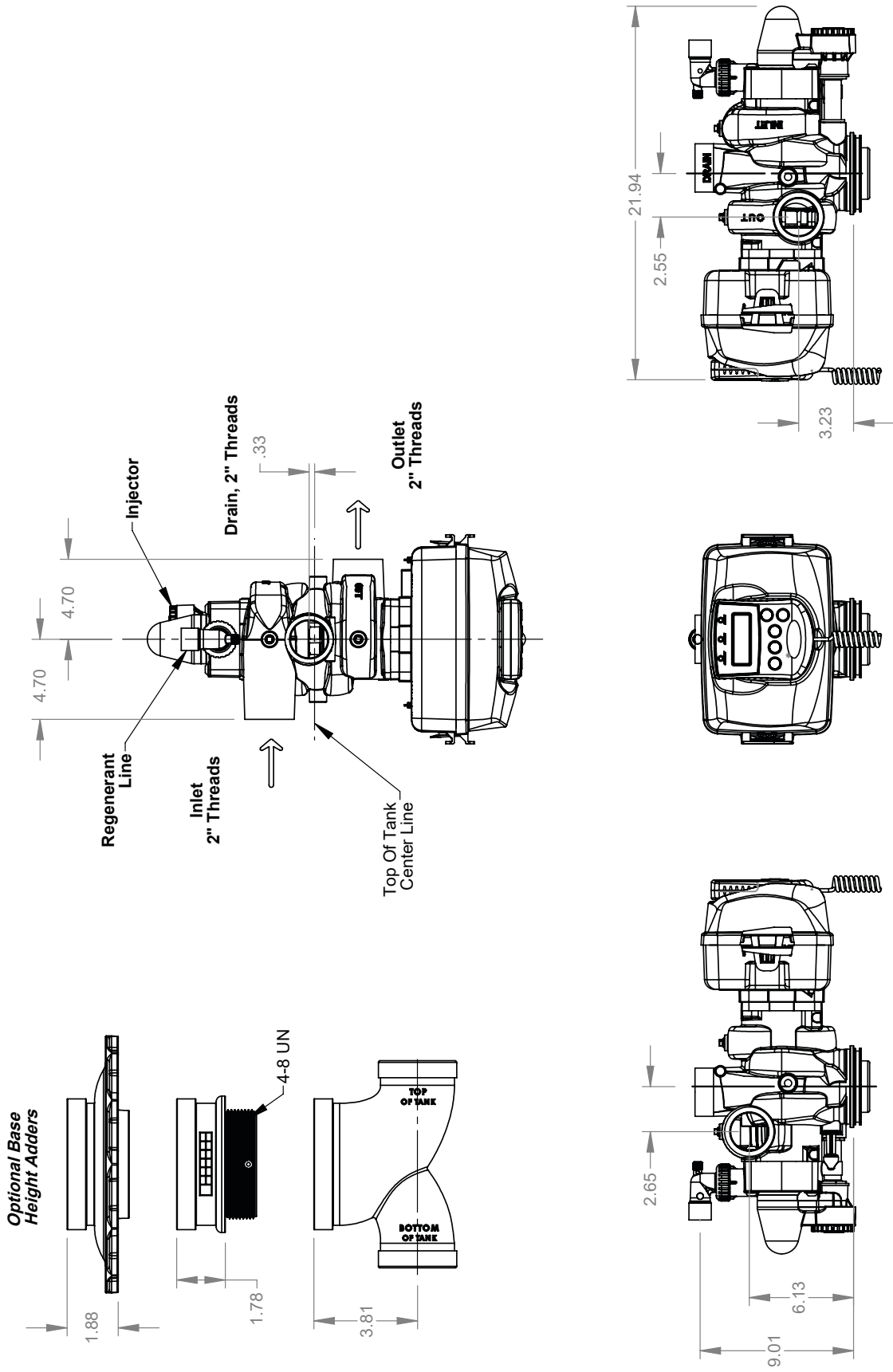

Installation

WS3

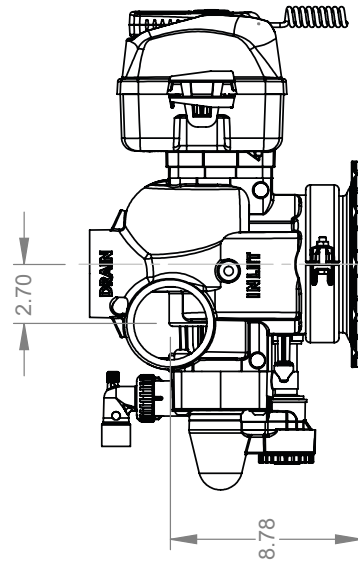
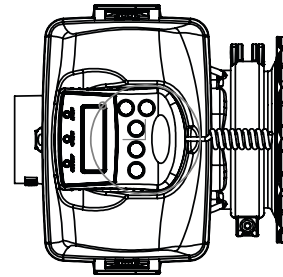
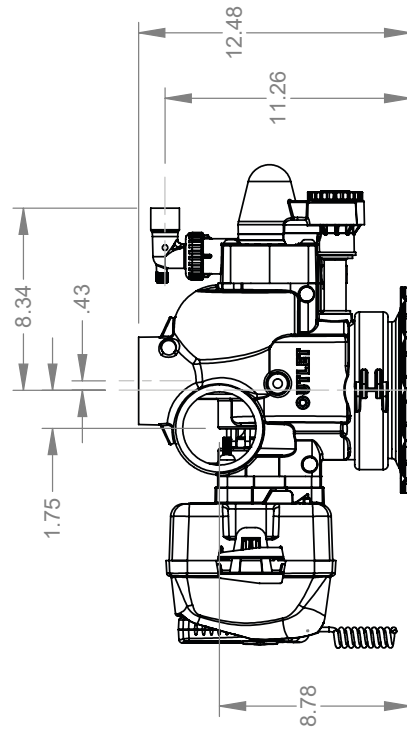
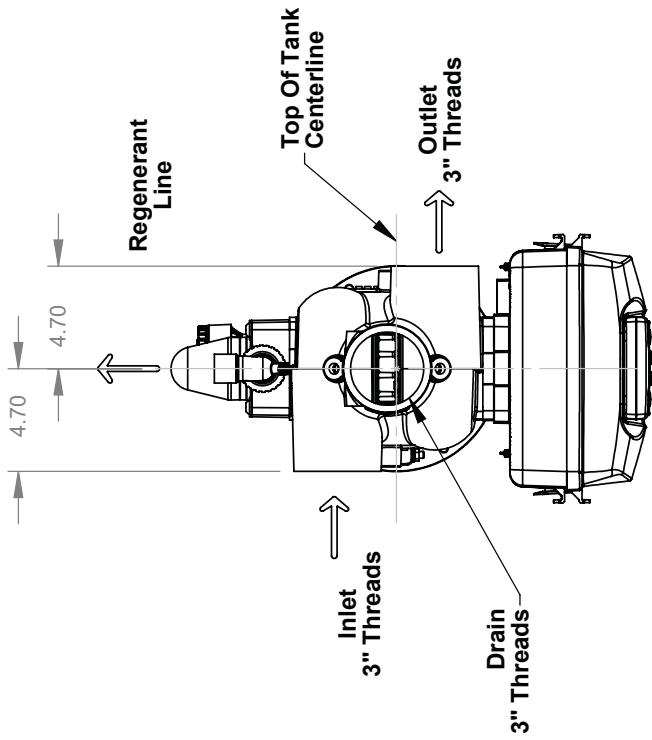
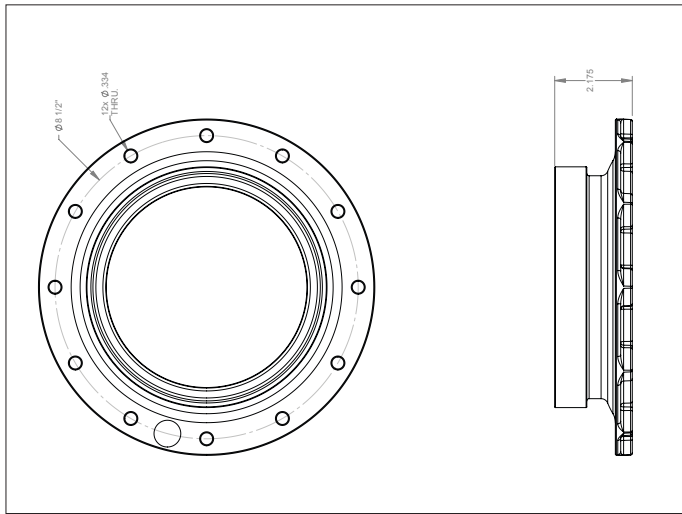

Installation

GENERAL INSTALLATION & SERVICE WARNINGS

The control valve and fittings are not designed to support the weight of the system or the plumbing.

Do not use Vaseline, oils, other hydrocarbon lubricants or spray silicone anywhere. A silicone lubricant may be used on black O-rings but is not necessary.

HYDROCARBONS SUCH AS KEROSENE, BENZENE, GASOLINE, ETC., MAY DAMAGE PRODUCTS THAT CONTAIN O-RINGS OR PLASTIC COMPONENTS. EXPOSURE TO SUCH HYDROCARBONS MAY CAUSE THE PRODUCTS TO LEAK. DO NOT USE THE PRODUCT(S) CONTAINED IN THIS DOCUMENT ON WATER SUPPLIES THAT CONTAIN HYDROCARBONS SUCH AS KEROSENE, BENZENE, GASOLINE, ETC.

THIS WATER METER SHOULD NOT BE USED AS THE PRIMARY MONITORING DEVICE FOR CRITICAL OR HEALTH EFFECT APPLICATIONS

Do not use pipe dope or other sealants on threads. Thread sealant tape is recommended to be used on all threads.

Use of pipe dope may break down the plastics in the control valve.



- **Slip Hazard:** Valve may leak during service.
- Keep areas free of water spills.



Disconnect from electrical power prior to servicing the valve.



Pressure hazard; depressurize valve before servicing.



- **INGESTION HAZARD:** This product contains a button cell or coin battery.
- **DEATH** or serious injury can occur if ingested.
- A swallowed button cell or coin battery can cause **Internal Chemical Burns** in as little as **2 hours**.
- **KEEP** new and used batteries **OUT OF REACH** of **CHILDREN**.
- **Seek immediate medical attention** if a battery is suspected to be swallowed or inserted inside any part of the body.

Service and maintenance should be performed by qualified personnel only.

Allow two feet of clearance to service WS2H, WS2HF, and WS3 valves.

The valve will withstand transportation and storage temperatures of -13 °F (-25 °C) to 131 °F (55 °C) and for short periods up to 158 °F (70 °C). If valve has been exposed to freezing conditions, let valve warm up to room temperature before running water through it. The valve has been packaged to prevent damage from the effects of normal humidity, vibration and shock.

SITE REQUIREMENTS:

- The plug-in Power adapter is for dry locations only
- The tanks should be on a firm, level surface
- Electrical: Use an uninterrupted outlet installed within 15 feet (4.57 meters) of the water conditioner.

All plumbing should be done in accordance with local codes.

1. Locate the water conditioner so the distance between the drain and the water conditioner is as short as possible.
2. Regenerant tanks that must be refilled should be located where they are easily accessible. It is recommended a safety brine valve be used.

Installation

3. Do not install any water conditioner with less than 10 feet of piping between its outlet and the inlet of a water heater.
4. Do not locate unit where it or its connections (including the drain and overflow lines) will ever be subjected to room temperatures under 40° F (4° C).
5. The use of resin cleaners in a non-vented enclosure is not recommended.

6. Inlet/Outlet Plumbing: Connect to a supply line downstream of outdoor spigots. Install inlet and outlet shutoff valves for the control valve; see top view drawings for control valve inlet and outlet locations. Installation of a three valve bypass is recommended. If using plastic fittings, ground the water conditioner per local electric codes. If an external water meter is used, install the water meter on the outlet side of the control valve. It is recommended that the meter assembly be installed horizontally or in a downflow vertical position to reduce turbine bearing wear. The turbine assembly may be oriented in any direction. Remove the cover and drive bracket and thread the water meter cord through the hole in the backplate. Reinstall the drive bracket. Weave the cord through the strain relief on the backplate and connect the end to the three prong connector labeled FLOW on the printed circuit board. Re-install the cover.

7. Drain: Verify that the drain can handle the backwash rate of the water conditioner. Correctly size the drain line and install an appropriately sized drain line flow control. For WS2H, WS2HF, and WS3 valves, a drain line flow control is NOT supplied with a valve. For WS2H and WS2HF valves, the drain outlet is 2" Female NPT or BSPT thread connection. For WS3 valves, the drain port is 3" Female NPT or BSPT connection. If using copper, solder joints near the drain must be done prior to connecting the drain line flow control fitting. Leave at least 6" (152.4 mm) between the drain line flow control fitting and solder joints to prevent heat from damaging the flow control. Avoid elevating the drain line above the control valve where possible. Discharge the drain line through an air gap to a receptacle in accordance with local plumbing codes.

IMPORTANT: Never insert a drain line directly into a drain, sewer line, or trap. Always allow an air gap between the drain line and the receptacle to prevent back siphonage.

8. Regeneration: If the control valve is to be used to regenerate the water conditioner with brine (saturated salt solution) or other regenerants. The WS2H, WS2HF, and WS3 control valves regenerant port has a 1" 90° Male NPT threaded outlet connection that swivels 360°. To ensure acceptable operation of the injectors, use 1" pipe to connect to the brine tank. Smaller drain line flow controls may result in the injector performance not matching the injector graphs. Use an adequately sized drain line flow control to ensure proper brine draw.

See Table 3 for injector order number and size for tank diameter. An overflow drain line from the regenerant tank that discharges into an acceptable drain is recommended, as a regenerant overflow could damage furnishings or the building structure. Connect a line to the overflow fitting on the regenerant tank. If an overflow fitting is not already installed on the regenerant tank, install one. Do not elevate the overflow drain line. Discharge the overflow drain line through an air gap to a receptacle in accordance with local plumbing codes.

9. Power Adapter: If a Power Adapter is already connected to the control valve, plug the Power Adapter into an uninterrupted outlet. If the Power Adapter cord has not yet been connected to the control valve, remove the control valve cover and the drive bracket and thread Power Adapter cord through the hole in the backplate. Re-install the drive bracket. Weave the cord through the strain relief on the backplate and connect the end to the four pin connector on the printed circuit board labeled POWER. Reinstall the cover. Plug the Power Adapter into an uninterrupted outlet.

10. Program the control valve: It is very important to program the control valve for the type of system (e.g. water softener or filter) and the end use application. Check the program used prior to testing the system.

EQUIPMENT IS NOT FOR USE IN AN ATEX ENVIRONMENT.

Installation

SUMMARY

Installation Date: _____

Installation Location: _____

Installer(s): _____

Phone Number: _____

Application Type: (Softener) _____ Other: _____

Water Source: _____

Water Test Results:

Hardness: _____ Iron: _____ pH: _____

Other: _____

Misc:

Service Flow Rates: min. _____ max. _____

Tank Size: Diameter _____ Height: _____

Resin or Media Volume: _____

Resin or Media Type: _____

Capacity: _____

Salt or Fill Setting per Regeneration: _____

Brine Tank Size: _____

Control Valve Configuration:

Valve Type: _____

Valve Part Number: _____

Valve Serial Number: _____

Regenerant Refill Control: _____ gpm/lpm

Injector Size: _____

Drain Line Flow Control: _____ gpm/lpm

Cycle Positions / Flow Diagrams

SERVICE

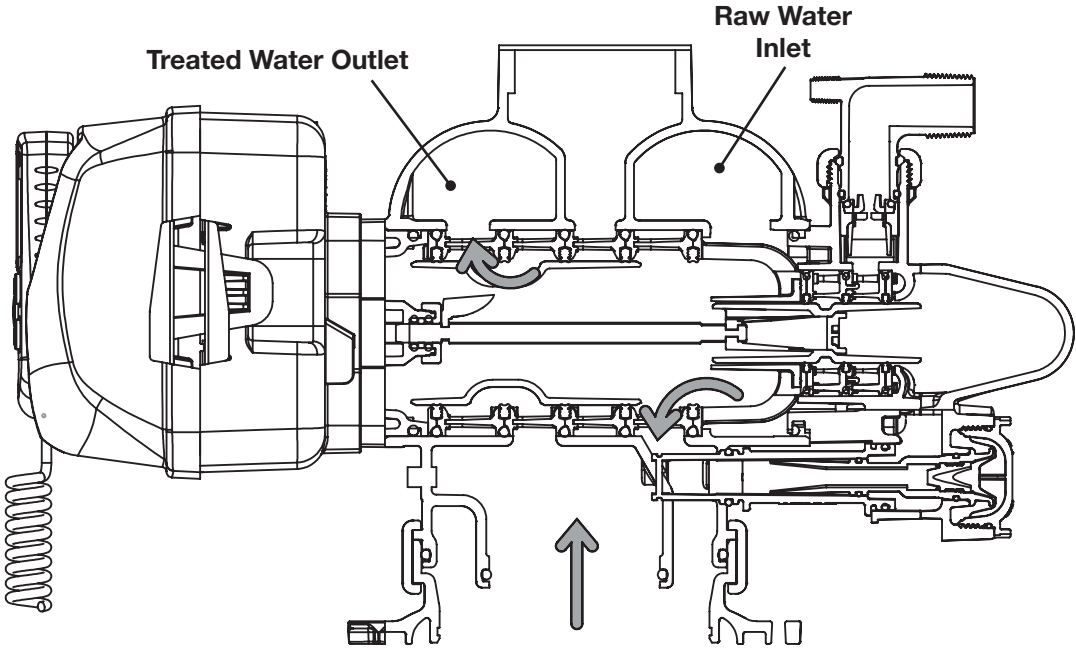

BACKWASH

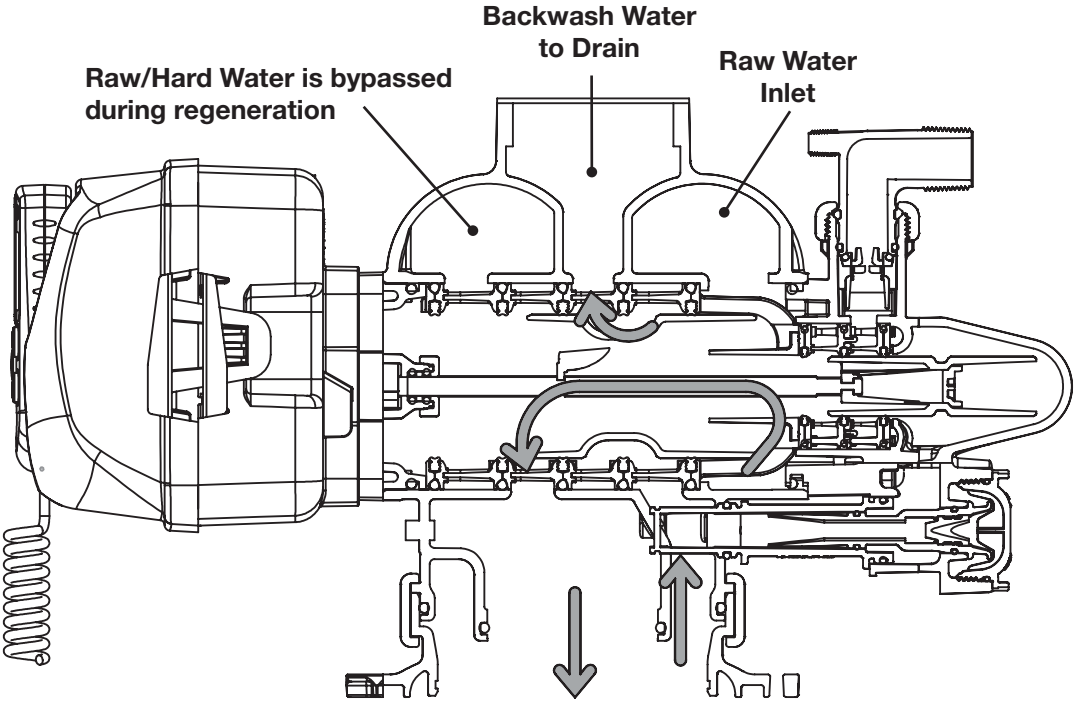

Cycle Positions / Flow Diagrams

DRAW

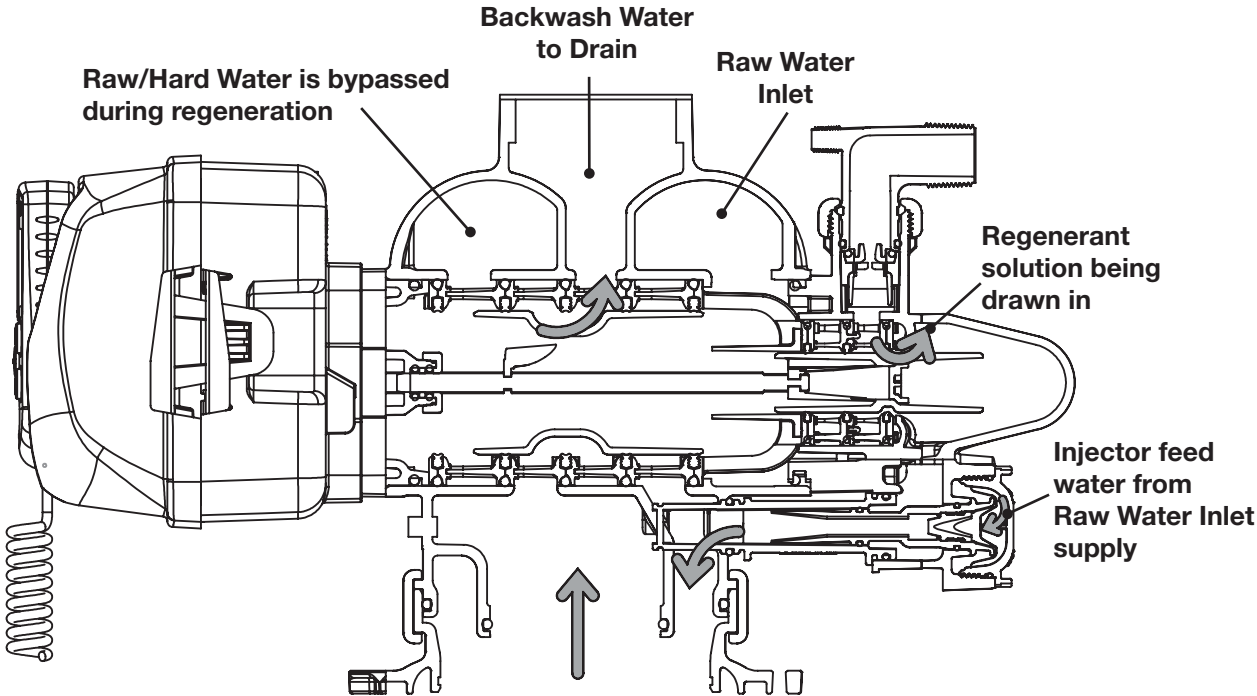

SLOW RINSE

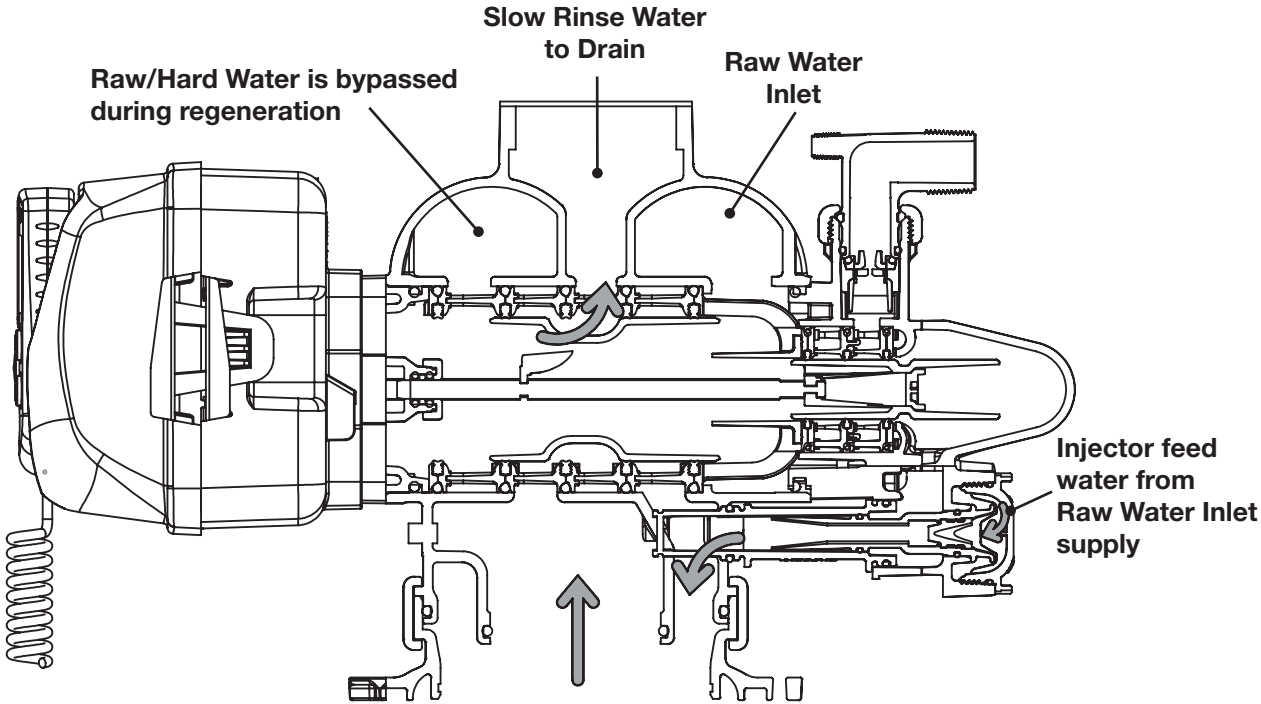

Cycle Positions / Flow Diagrams

RINSE

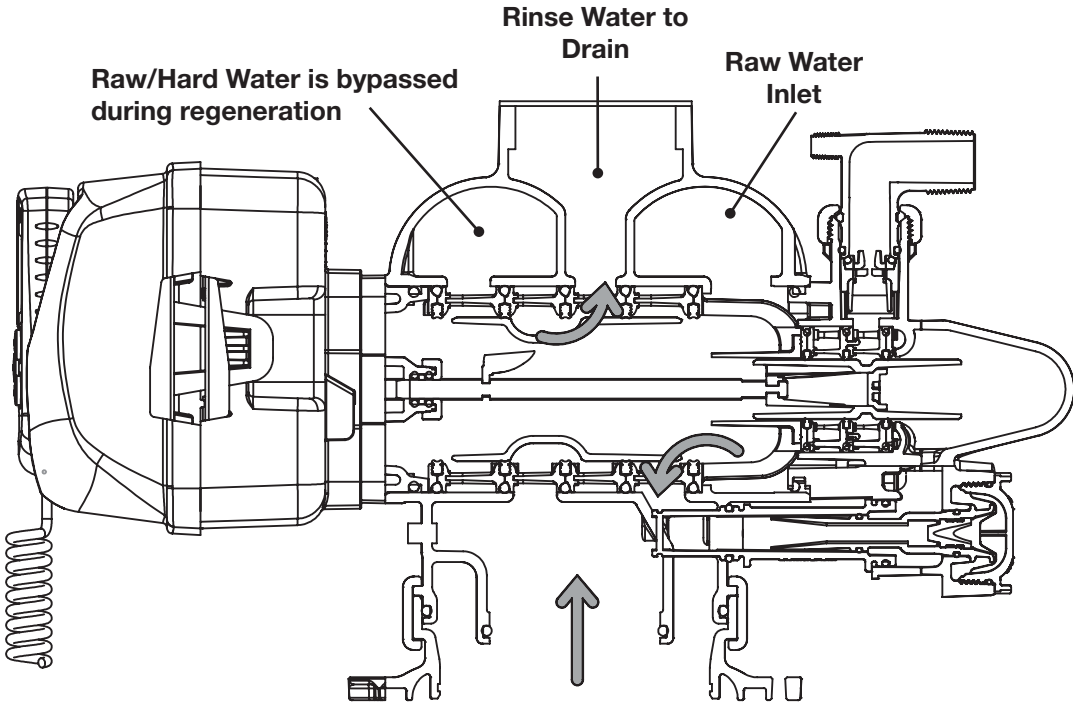

SOFT WATER REFILL

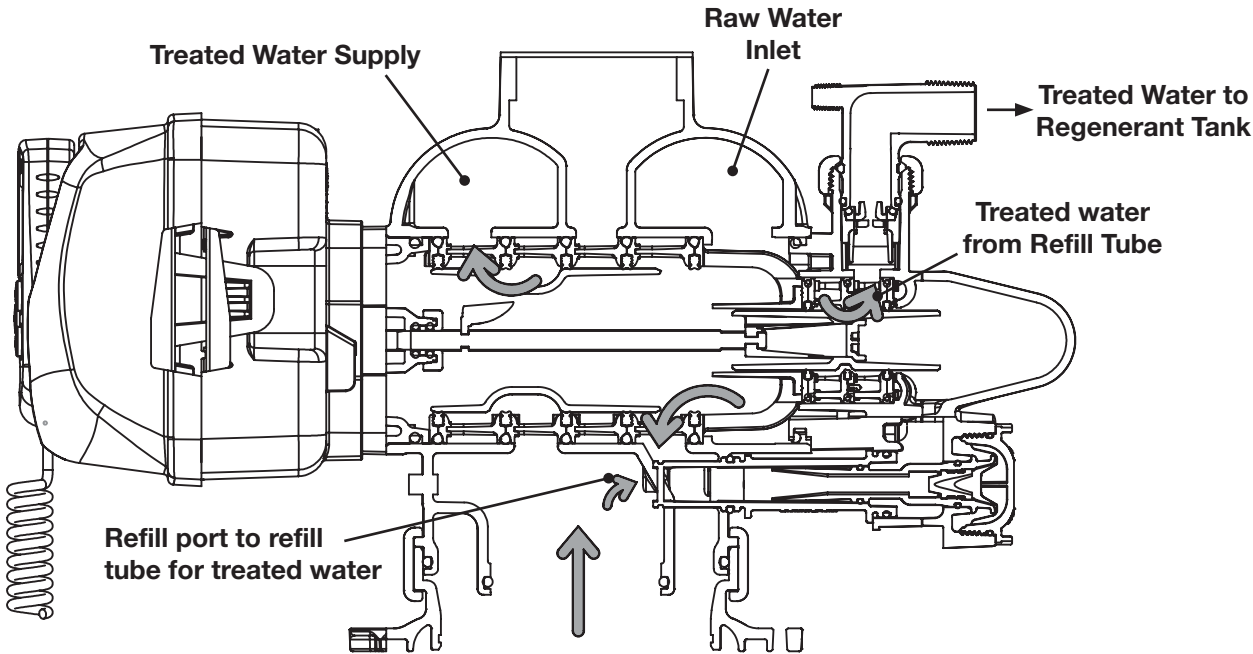

Cycle Positions / Flow Diagrams

FRONT COVER AND DRIVE ASSEMBLY

Drawing No.	Order No.	Description	Quantity
1	V3068-01	WS2H/3 POD FRONT/BACK COVERS	1
1a	V3082-01*	WS2H/3 GRAPHICS POD ASY W/BRD	Optional
2	V3241-02BOARD	WS2H/3 DISPLAY GRPH POD PCB REPL	1
3	V3248-01	WS2H/3 GRAPHICS POD CABLE	1
4	V3242-03BOARD	WS2H/3 VLV W/ MODBUS PCB REPL	1
5	V3224-01R	WS2H/3 COVER ASY PLATINUM	1
6	V3107-01	WS1 MOTOR ASY	1
7	V3226-01	WS2H/3 DRIVE BRACKET ASY	1
8	V3110	WS1 DRIVE GEAR 12X36	3
9	V3109	WS1 DRIVE GEAR COVER	1
Not Shown	V3461-02	WS2H/3 24VDC 0.8A PWR SUPPLY	1
	V3461EU-02	WS2H/3 24VDC 0.8A EU PWRSUPPLY	
	V3461UK-02	WS2H/3 24VDC 0.8A UK PWRSUPPLY	
10	V4427	WS2H/3 PCB RELAY EXP KIT	Optional

*Contains items 1,2 & 3 Pod Assembly, PC Board and Cable

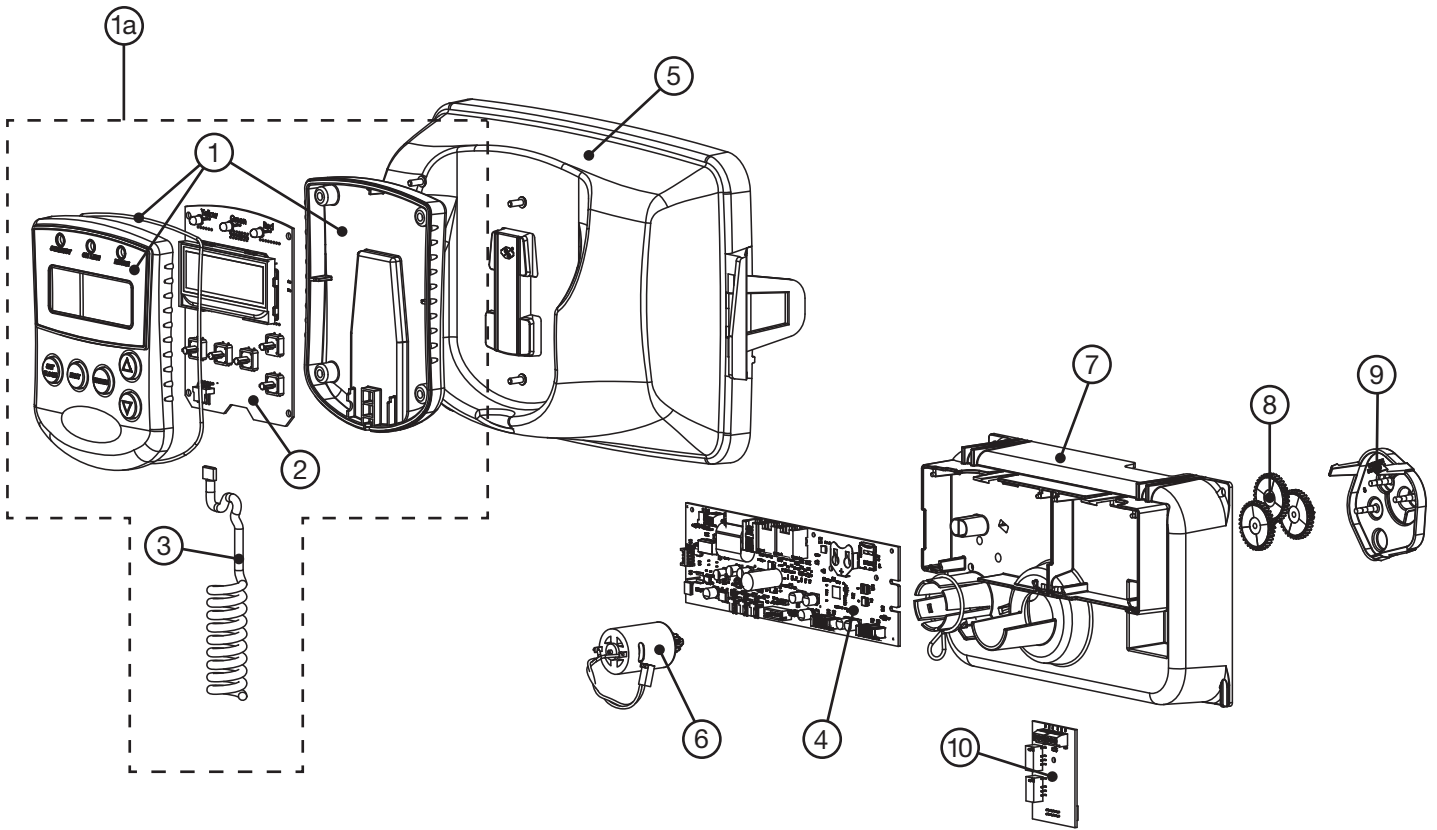

Cycle Positions / Flow Diagrams

DRIVE CAP ASSEMBLY, DOWNFLOW PISTON, REGENERANT PISTON, SPACER STACK ASSEMBLY, DRIVE BACKPLATE AND MAIN BODY

Drawing No.	Order No.			Description	Quantity
	2H	2HF	3"		
1	V3275			3/8-16 x 2 1/4 SS Screw	4
2	V3291			3/8 Washer SS	4
3	V3225			Backplate	1
4	V3066	V3093		Drive Assembly	1
5	V3289			Drive Cap O-ring	1
6	V3204-01	V3666-01		Main Piston	1
7	V3238-01***			Brine Piston	1
8	V3065	V3092		Seal Spacer Stack	1
Not Shown	V3468-04			1/4" Plug, NPT (Black)	2
	V3465-04			1/4" Plug, BSPT (Gray)	
9	V3201-03	V3201-01HF	V3667-01	Main Body, NPT	1
	V3201BSPT-03	V3201BSPT-01HF	V3667BSPT-01	Main Body, BSPT	
10	V3279		V3763	Base O-ring	1
11	V3280		V3762	Riser O-ring NPT	1
	V3452			Riser O-ring BSPT	
12	V3054**		V3091**	Base Clamp Assembly	1
13	V3276			Base Clamp Bolt 5/16-18 x 1 3/4 SS	1
14	V3269			Hex Nut 5/16-18 SS	1

**V3054 and V3091 WS2 4 IN BASE CLAMP ASY includes a V3276 WS2 BOLT HEX SS 5/16-18X1-3/4 and V3269 WS2 NUT 5/16-18 SS HEX.

***V3238-01 Brine Piston is used for Backwash Only valves.

THIS WATER METER SHOULD NOT BE USED AS THE PRIMARY MONITORING DEVICE FOR CRITICAL OR HEALTH EFFECT APPLICATIONS.

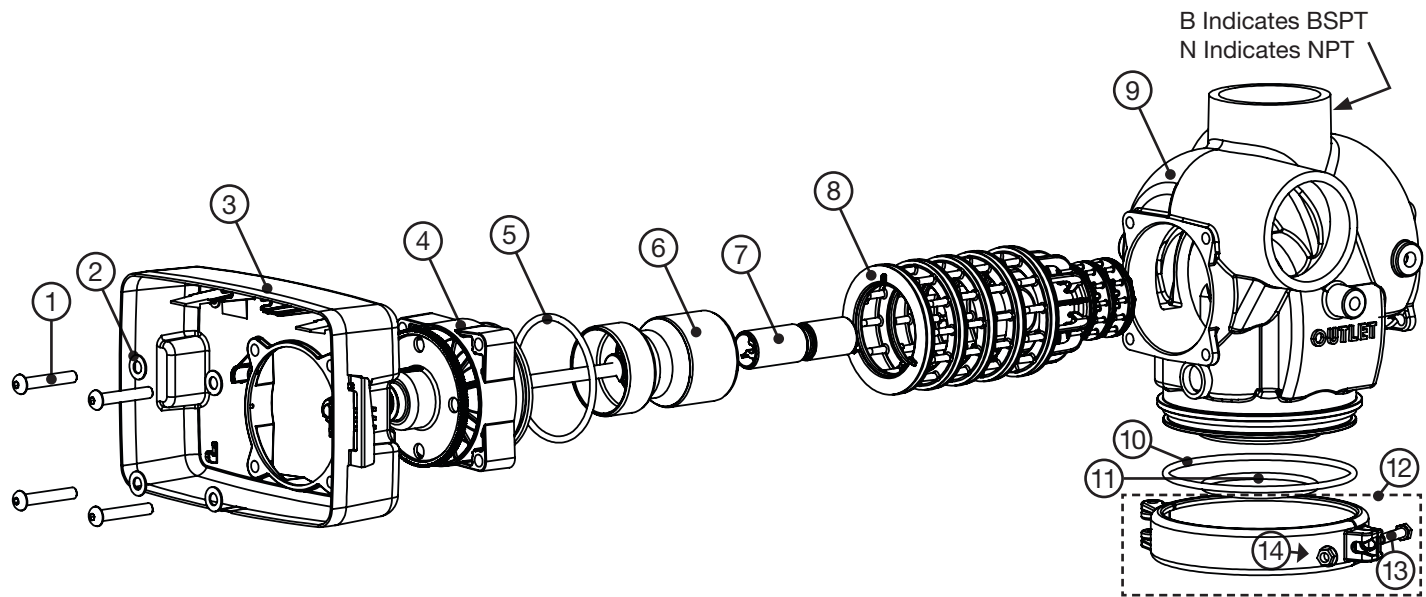

Cycle Positions / Flow Diagrams

INLINE FLOW METER ASSEMBLY

Drawing No.	Order No.			Description	Quantity
	2H	2" Meter	3" Meter		
1	V3003-02	V3003-02		WS1.5/2H Meter Commercial Asy	1
			V3039	WS3 Meter Asy 4FT	
		V3221	V3221	WS Remote Meter Asy 15FT	
2		V3632		Commercial Meter Retaining Clip	1
3		V3118-03		Turbine Asy	1
4		V3501		Commercial Meter Turbine Clip	1
5		V3105		O-ring - 215	1

Service or replace the turbine by:

1. Turn the bypass for the system off and relieve the pressure on the system.
2. Press downward on the remote meter assembly to relieve tension on the retaining clip V3632 (or the U-shaped V3223 WS2 Meter Clip). Remove the clip and take the meter assembly out of the housing.
3. Remove the bend from the two exposed tips of the retaining clip V3501 and remove clip.
4. Service or replace the V3118-03 WS15/2 Turbine Assembly and place it back in the turbine shaft.
5. Insert the V3501 WS15/2 Turbine Clip and re-bend the exposed ends of the clip. The V3118-03 turbine has a groove to line up with the V3501 WS15/2 Turbine Clip.
6. Insert meter assembly back into the meter housing.
7. Re-install the meter retaining clip V3632 as shown below (or the U-shaped V3223 WS2 Meter Clip).
8. Open the bypass for the system slowly to bring back into service and check to be sure you have no water leaks.

Typical meter retaining clip installation. Ensure clip is fully engaged in groove and tabs positioned in slot as shown.

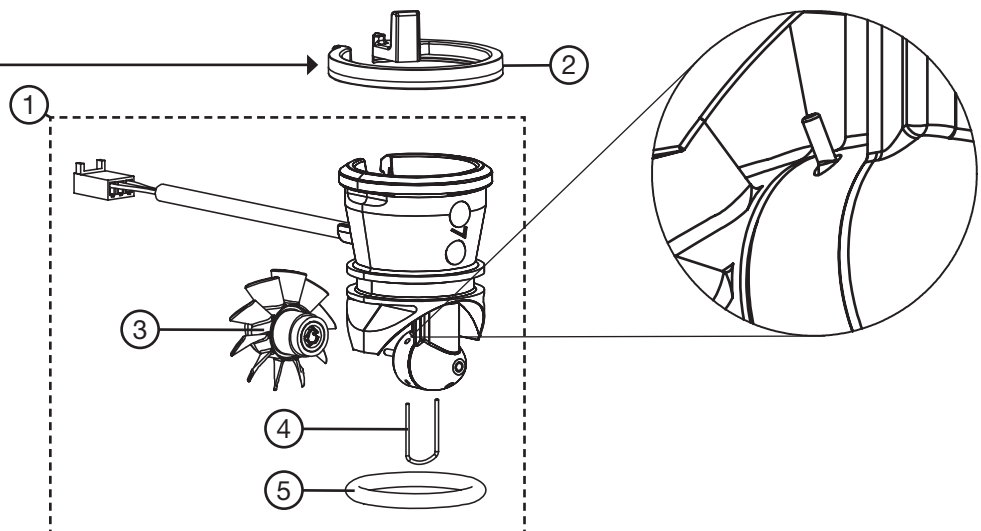
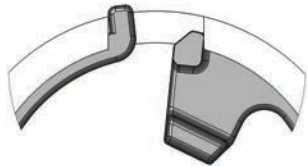

Cycle Positions / Flow Diagrams

WS2H, WS2HF, AND WS3 BRINE VALVE BODY AND INJECTOR COMPONENTS

Drawing No.	Order No.	Description	Quantity
1	V3237-01	WS2H/3 SOFTFILL TUBE ASY	1
2	V3236-04*	WS2H INJECTOR TUBE ASY FOR A THRU H	1
3	V3289	O-RING 344	1
4	V3067	WS2H/3 BRINE BODY ASY	1
5	V3477	WS2H/3 INJECTOR CAP	1
6	V3152	O-RING 135	1
7	V3275	WS2H/3 SCREW BSHD SS 3/8-16X2-1/4 (7/32" hex allen wrench required)	4
8	V3291	WS2H/3 WASHER SS 3/8	4
9	V3162-022**	WS1 DLFC 022 FOR 3/4	1
10	V3231	WS2H/3 REFILL FLOW CNTRL RETAINER	1
11	V3277	O-RING 211	1
12	V3105	O-RING 215	1
13	V3150	WS1 SPLIT RING	1
14	V3151	WS1 NUT 1 QC	1
15	V3149	WS1 FTG 1 MALE NPT ELBOW	NPT Only
	V3797	WS1 FTG 1 MALE BSPT ELBOW	BSPT Only
16	V3010-XX	See WS2H and WS3 Valve Injector Order Information table below ²	1
17	V3499***	WS2H/3 FITTING CAP 1 IN THREADED	1
Not Shown	V3189	WS1 FTG 3/4&1 PVC SLVNT 90	Optional

* V3236-04 WS2H INJECTOR TUBE ASY A thru H contains a V3285 O-RING 213 and a V3286 O-RING 216. WS3 BSPT valves manufactured before January 7, 2021 and WS3 NPT valves manufactured before August 25, 2021 use a V3670-01 Injector Tube. V3670-01 WS3 INJECTOR TUBE DOWNFLOW ASY contains a V3285 O-RING 213, V3286 O-RING 216 and a V3163 O-RING 019.

** Any V3162-XXX flow control may be used. V3237-01 WS2H SOFTFILL TUBE ASY contains a V3155 O-RING 112, V3287 O-RING 110 and a V3288 O-RING 206.

*** Install V3499 on V3149 if valve is to be set up as a backwash only valve.

WS2H AND WS3 VALVE INJECTOR ORDER INFORMATION

Injector Order Number	Typical Tank Diameter ¹
V3010-2A	18"
V3010-2B	21"
V3010-2C	24"
V3010-2D	30"
V3010-2E	36"
V3010-2F	42"
V3010-2G	48"
V3010-2H	63"

¹ Actual injector size used may vary depending on the design and application of the system. Injectors in table are sized for a typical downflow softener using standard mesh synthetic cation exchange media regenerating with sodium chloride.

² V3010-2A through V3010-2G injectors contain a V3283 O-RING 117 and a V3284 O-RING 114. V3010-2H injectors use a V3283 O-RING 117 and D1263 O-RING 116. Backwash Only Valves include a V3499 but do not include the following parts: V3189, V3162-022, V3231 and V3277.

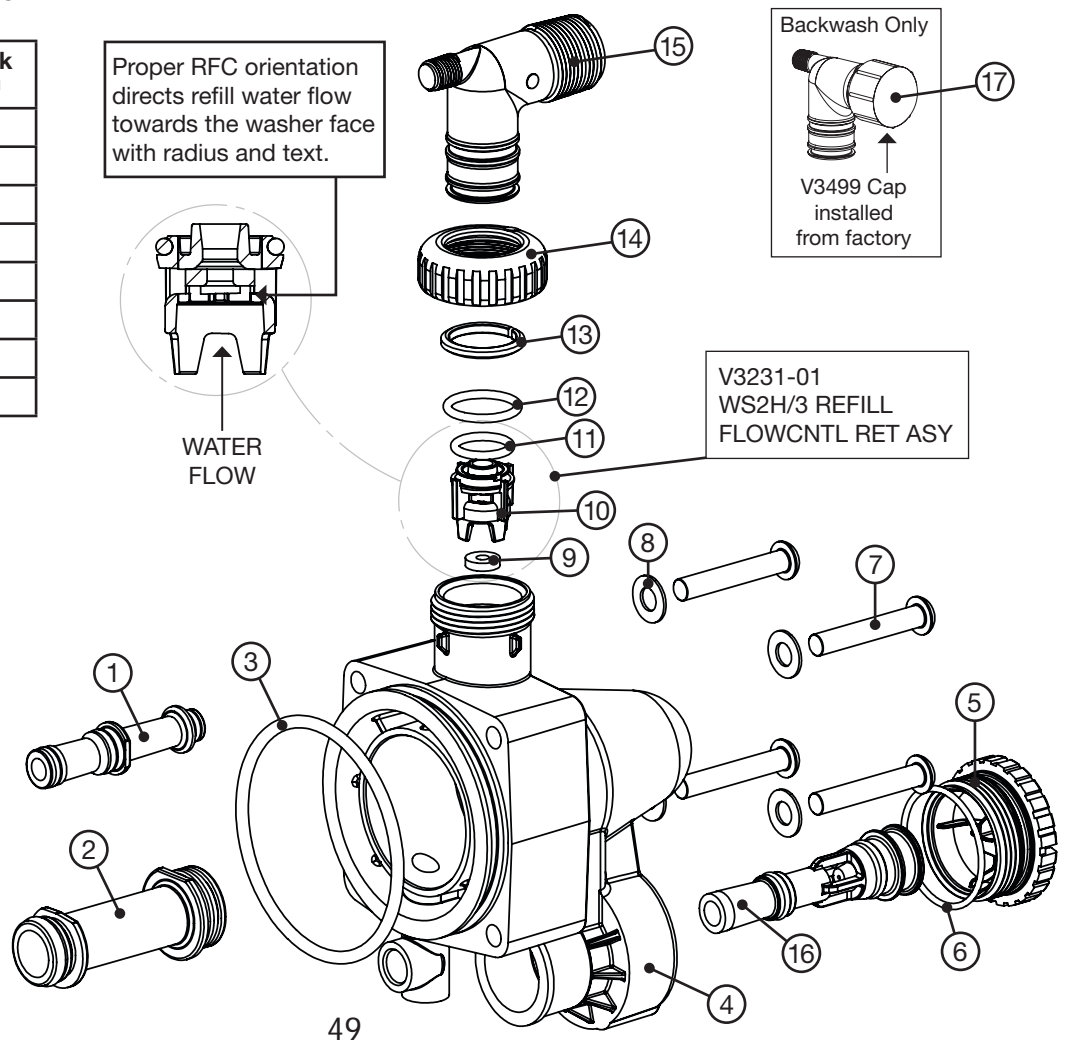

Cycle Positions / Flow Diagrams

STANDARD INJECTOR GRAPHS

Order No. V3010-2A
US Units

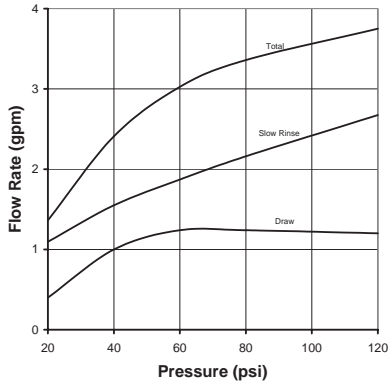

Order No. V3010-2B
US Units

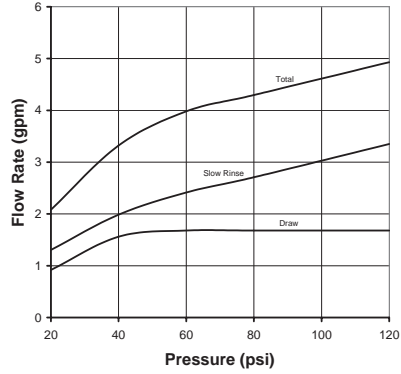

Order No. V3010-2C
US Units

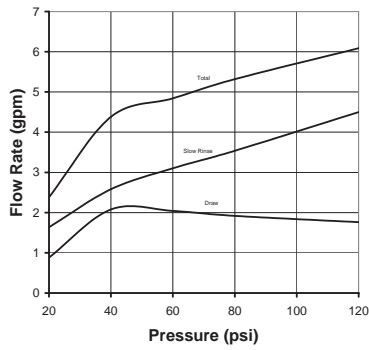

Order No. V3010-2D
US Units

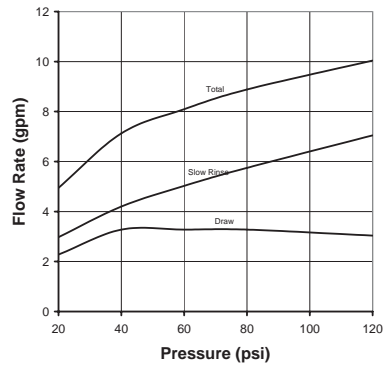

Order No. V3010-2E
US Units

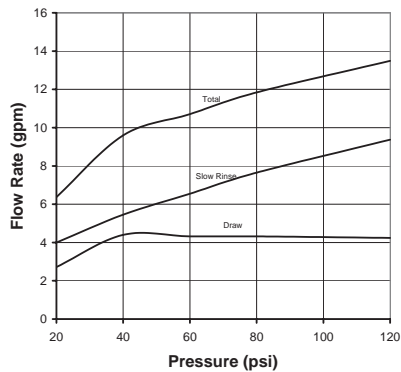

Order No. V3010-2F
US Units

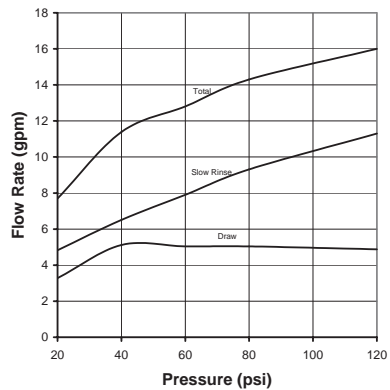

Order No. V3010-2G
US Units

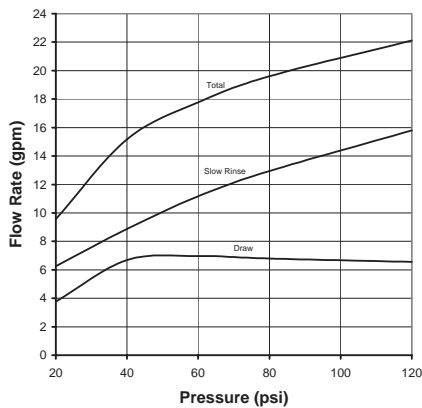

Order No. V3010-2H
US Units

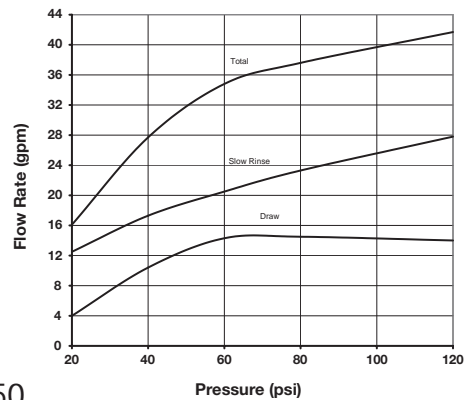

Cycle Positions / Flow Diagrams

STANDARD INJECTOR GRAPHS (CONTINUED)

**Order No. V3010-2A
Metric Units**

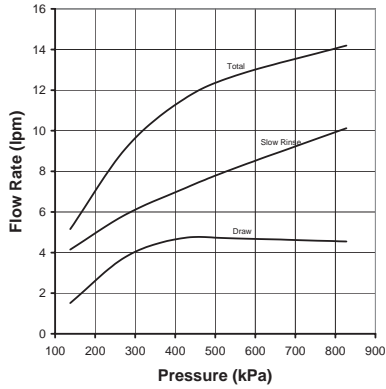

**Order No. V3010-2B
Metric Units**

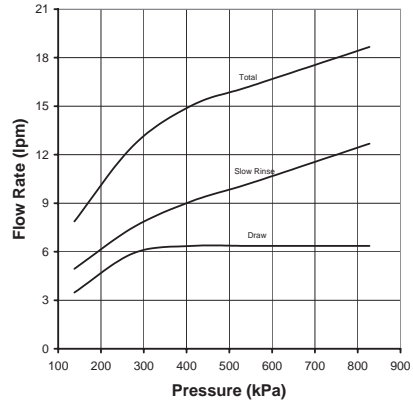

**Order No. V3010-2C
Metric Units**

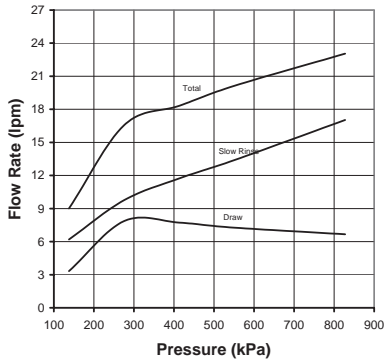

**Order No. V3010-2D
Metric Units**

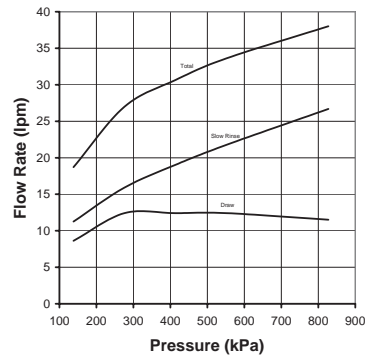

**Order No. V3010-2E
Metric Units**

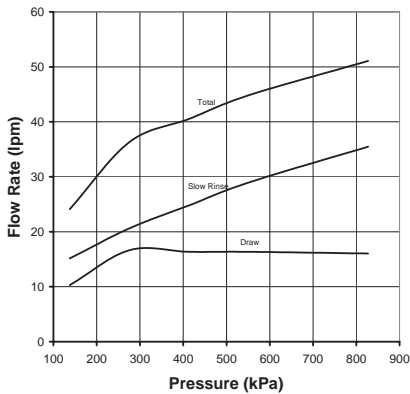

**Order No. V3010-2F
Metric Units**

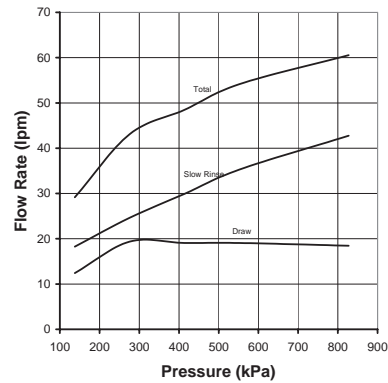

**Order No. V3010-2G
Metric Units**

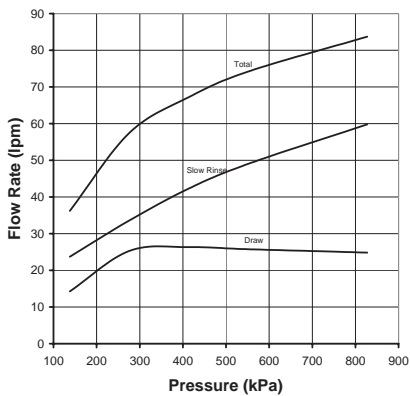

**Order No. V3010-2H
Metric Units**

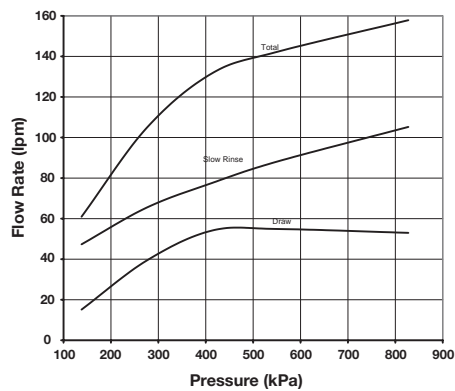

Cycle Positions / Flow Diagrams

V3064 WS2H/2QC 4 INCH BASE ASY (FOR USE ON WS2H OR WS2QC ONLY)

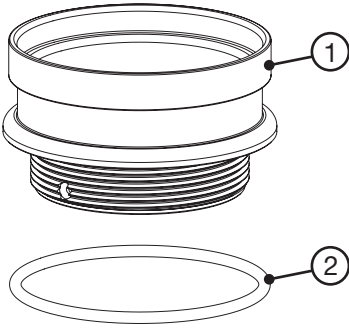

Drawing No.	Order No.	Description	Quantity
1	V3202-01	WS2H BASE	1
2	V3419	O-RING 347	1

V3055 WS2H/2QC 6 INCH FLANGE BASE ASY or V3090 WS3 6 INCH FLANGE BASE ASY

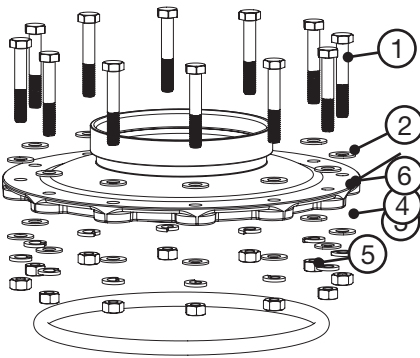

Drawing No.	Order No.	Description	Quantity	
			V3055	V3090
1	V3444	WS2H SCREW HEXCAP 5/16-18X2 SS	12	12
2	V3293	WS2H WASHER SS 5/16 FLAT	24	24
3	V3445	WS2H WASHER SPLIT LOCK 5/16 SS	12	12
4	V3447	NUT HEX 5/16-18 SILICON BRASS	12	12
5	COR60FL	O RING 6 FLANGE ADAPTER	1	1
6	V3261-01	WS2H FLANGE BASE	1	
	V3671-01	WS3 FLANGE BASE		1

UPPER DIFFUSERS

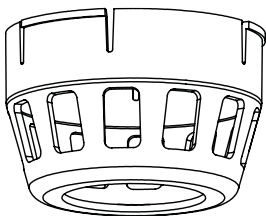

Order No.	Description
D1300-01	2" RISER DIFFUSER
V3672	3" RISER UPPER DIFFUSER

SIDE MOUNT BASE ASSEMBLY

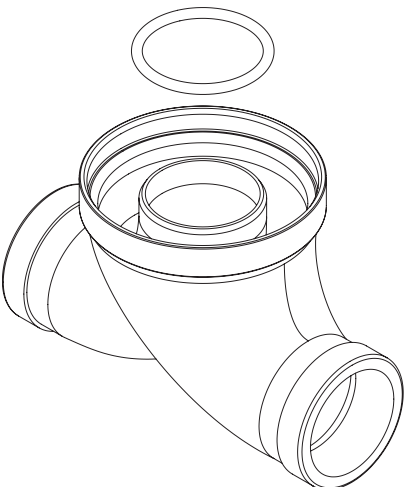

Order No.	Description	Inlet/Outlet
V3260-02	2" Sidemount, NPT	2" Female NPT or 2.5" Groove Lock
V3260BSPT-02	2" Sidemount, BSPT	2" Female BSPT or 2.5" Groove Lock
V3674-02	3" Sidemount, NPT	3" Female NPT
V3674BSPT-02	3" Sidemount, BSPT	3" Female BSPT

When using a side mount base with WS2H, WS2QC, or WS2HF BSPT valves replace distributor pilot O-ring V3452 O-RING 230 with V3280 O-RING 332. See exploded view of WS2H, WS2QC, or WS2HF valve for specific location of distributor pilot O-ring.

Cycle Positions / Flow Diagrams

DRAIN LINE FLOW CONTROLS

All drain line flow control housings are shipped without flow control washers. See drain line flow control washer section for available flow selections.

PVC Elbow, 0.7 - 10 GPM

Item	Part#	Description	Qty.
	V3158-04	WS Drain Fitting, 3/4" Elbow	
1	V3158-03	Drain Elbow, 3/4 NPT	1
2	V3159-01	DLFC Retainer Assembly	1
3	V3163	O-ring, -019	1
4	H4615	Locking Clip	1
5*	V3983	WS2 DLFC Adapter	1
6	V3162-xx	See DLFC Section	1

*Also available: V3414 WS1.5 DLFC Adapter

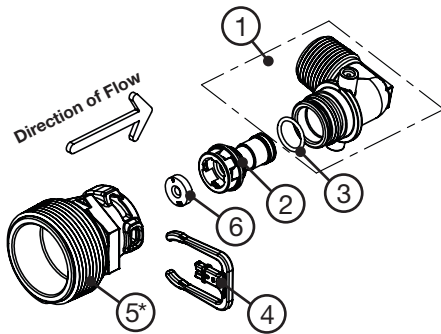

Inline Plastic, 9 - 25 GPM

Item	Part#	Description	Qty.
	V3008-05	WS Drain Fitting, 1" Straight	
1	V3167	WS Drain Fitting Adapter, 1" NPT	1
2	V3166-01	Drain Fitting Body	1
3	V3151	WS1 Nut, QC	1
4	V3150	WS1 Split Ring	1
5	V3105	O-ring -215	1
6	V3163	O-ring -019	1
7	H4615	Locking Clip	1
8**	V3983	WS2 DLFC Adapter	1
9	V3190-xx	See DLFC Section	1

**Also available: V3414 WS1.5 DLFC Adapter

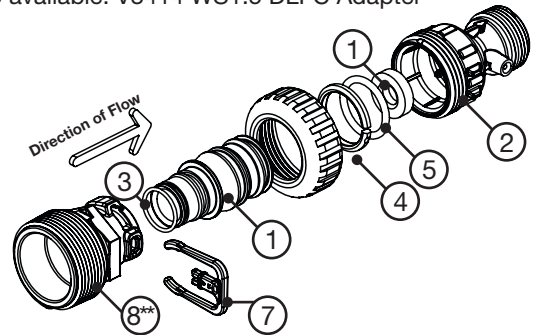

Stainless Steel, 9 - 85 GPM

Drawing No.	Order No.	Description	Quantity			
			V3079	V3079BSPT	V3080	V3080BSPT
1	V3081	WS15 RETAINER DLFC ASY	1	1	1	1
2	V3645	WS15 DLFC FLANGE OUTLET FNPT	1		1	
	V3645BSPT	WS15 DLFC FLANGE OUTLET FBSPT		1		1
3	V3646	WS15 DLFC FLANGE INLET MNPT			1	1
4	V3388	WS125 DLFC FLANGE INLET MNPT	1	1		
5	V3652	B S 5/16-18x3/4	4	4	4	4
6	V3441	O-RING 226	1	1	1	1
7	V3162-xx	See DLFC Table	0-6	0-6	0-6	0-6
8	V3190-xx	See DLFC Table	1	1	1	1

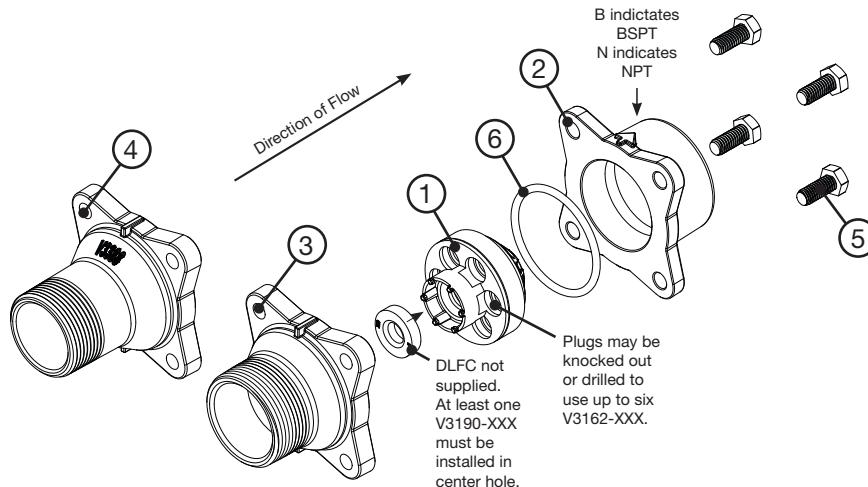

Cycle Positions / Flow Diagrams

M X F STAINLESS STEEL, 0.7 – 150 GPM

Drawing No.	Order No.	Description	Quantity	
			V3051	V3051BSPT
1	V3052	WS2 DLFC Retainer Asy	1	1
2	V3245	WS2 DLFC Flange Inlet NPT	1	
	V3245BSPT	WS2 DLFC Flange Inlet BSPT		1
3	V3246	WS2 DLFC Flange Outlet NPT	1	
	V3246BSPT	WS2 DLFC Flange Outlet BSPT		1
4	V3273	Bolt Hex Hd S/S HCS 3/8-16x3/4	4	4
5	V3278	O-ring 338	1	1
6	V3162-XX	See DLFC table	0-5	0-5
7	V3190-XX	See DLFC table	0-4	0-4

Assemblies are shipped without drain line flow control (DLFC). Assembly instructions:

1. Determine the desired flowrate. Select a combination of V3162-XXX's and V3190-XXX's to arrive at the desired flow rate. Up to five of the smaller V3162-XXX's may be used. Up to four of the larger V3190-XXX's may be used.
2. Using a drill or punch, remove the desired knockout(s) in V3052.
3. Smooth hole(s).
4. Install appropriate size(s) of drain line flow control washers. Pay close attention to proper DLFC orientation.
5. Assemble. Properly orient the V3052 in the direction of flow.
6. Inlet and outlet threads are 2". Couplings for iron pipe may also be used.

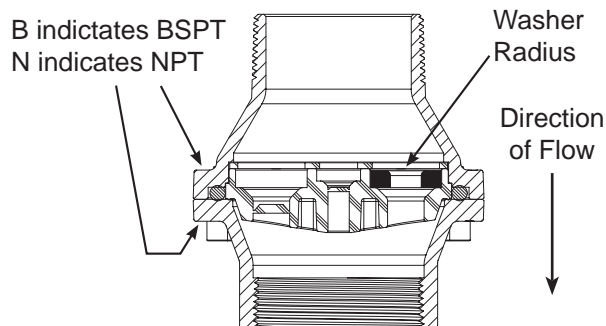
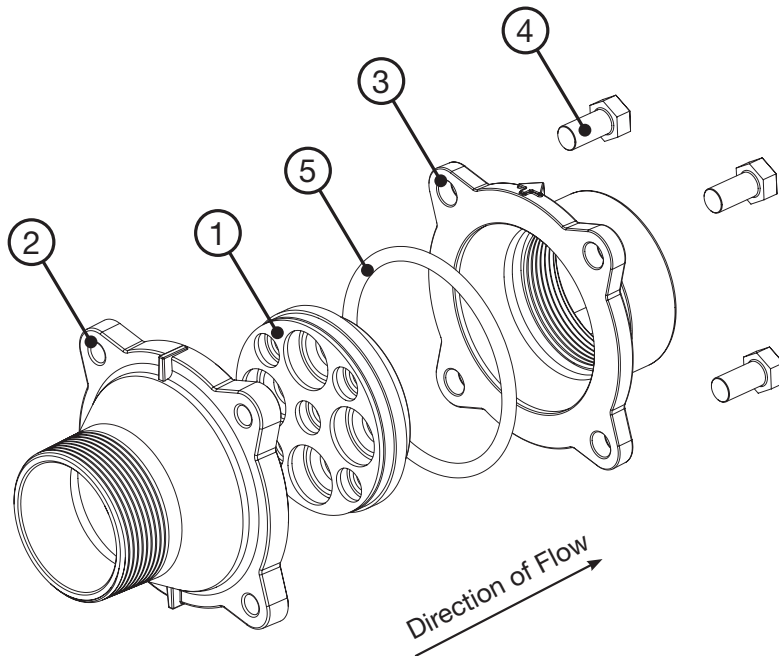

Cycle Positions / Flow Diagrams

MXF STAINLESS STEEL, 9-225 GPM

Drawing No.	Order No.	Description	Quantity	
			V3764	V3764BSPT
1	V3765-01	WS3 DLFC HOUSING NPT	1	
	V3765BSPT-01	WS3 DLFC HOUSING BSPT		1
2	V3766	WS3 DLFC RETAINER	1	1
3	V3767	WS3 DLFC RETAINER COVER	1	1
4	V3768	WS3 DLFC RETAINER RING	1	1
5	V3769	O-RING 336	1-2	1-2
6	V3190-XX	See DLFC table	1-9	1-9

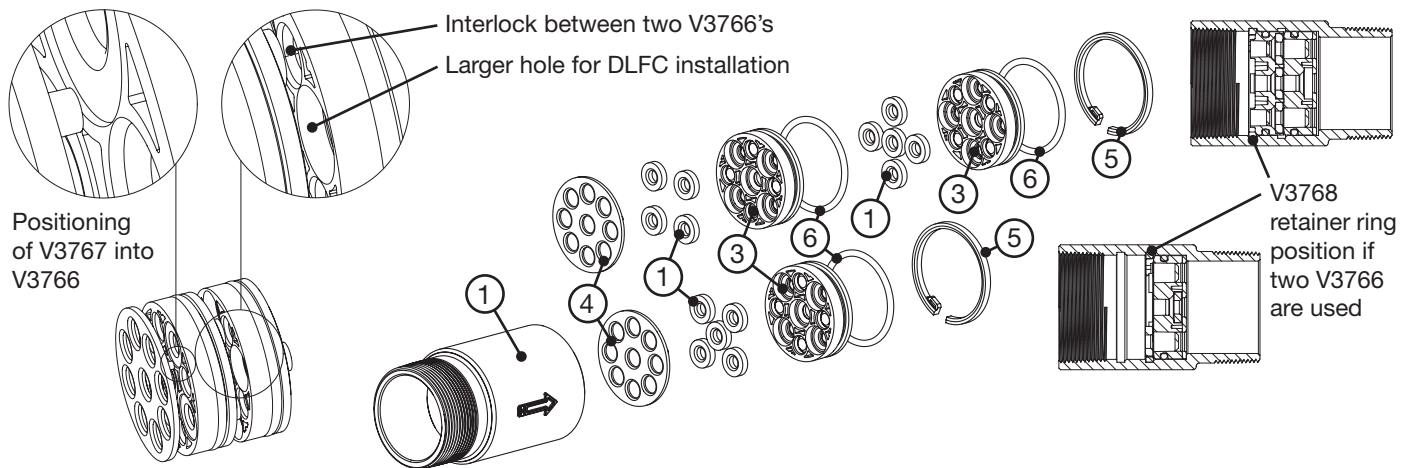

Assemblies are shipped without drain line flow control (DLFC) washers.

Assembly instructions:

1. Determine the desired flow rate. Select a combination of V3190-XXX's to arrive at the desired flow rate.
2. Using a drill or punch, remove the desired knockout(s) in V3766. Each V3766 retainer contains two types of knockouts. The larger knockouts are removed to install a DLFC. If two V3766 retainers are needed, remove the smaller diameter knockout that lines up with the DLFC installed in the other retainer. One or two V3766 retainers may be used. When using one V3766 retainer, V3190-XXX must be installed in the center hole. When using two V3766 retainers, a V3190-XXX must be installed in the center hole of one of the retainers and the center hole on the other retainer must remain open.
3. Smooth hole(s).
4. Install appropriate size(s) of drain line flow control washers. Pay close attention to proper DLFC orientation.
5. Assemble. Each V3766 retainer, must have a V3769 O-ring installed. One each of the V3767 retainer cover and V3768 retainer ring must be used whether one or two V3766 retainers are used. The positioning of the V3768 retainer ring varies depending on the number of V3766 retainer(s) used. Properly orient the V3766(s) in the direction of flow.
6. Properly orient the complete assembly in the direction of flow. Inlet and outlet threads are 3".

Cycle Positions / Flow Diagrams

DRAIN LINE FLOW CONTROL WASHERS

Order No.	Description
V3162-007	0.7 GPM Drain line flow control
V3162-010	1.0 GPM Drain line flow control
V3162-013	1.3 GPM Drain line flow control
V3162-017	1.7 GPM Drain line flow control
V3162-022	2.2 GPM Drain line flow control
V3162-027	2.7 GPM Drain line flow control
V3162-032	3.2 GPM Drain line flow control
V3162-042	4.2 GPM Drain line flow control
V3162-053	5.3 GPM Drain line flow control
V3162-065	6.5 GPM Drain line flow control
V3162-075	7.5 GPM Drain line flow control
V3162-090	9.0 GPM Drain line flow control
V3162-100	10.0 GPM Drain line flow control
V3190-090	9.0 GPM Drain line flow control
V3190-100	10.0 GPM Drain line flow control
V3190-110	11.0 GPM Drain line flow control
V3190-130	13.0 GPM Drain line flow control
V3190-150	15.0 GPM Drain line flow control
V3190-170	17.0 GPM Drain line flow control
V3190-200	20.0 GPM Drain line flow control
V3190-250	25.0 GPM Drain line flow control

All DLFC housings ship without DLFC installed.
 Select control from table for proper backwash,
 based on media manufacturer's recommendations.

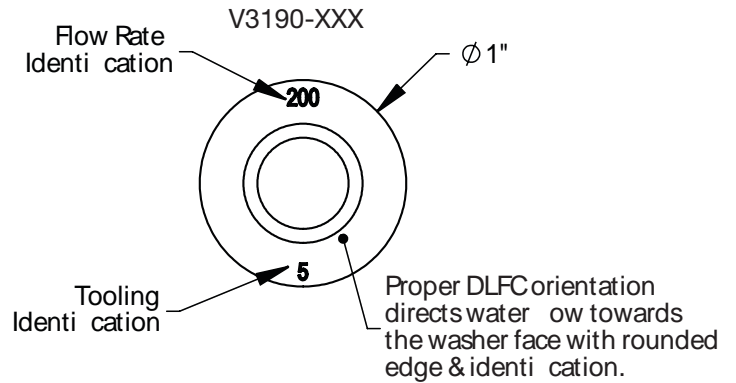
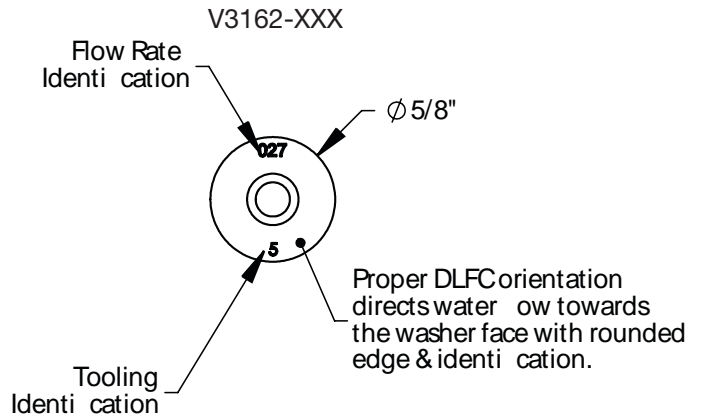

Troubleshooting Guide

WS2HF & WS3 ERROR CODES

Possible Errors	
Code	Description
1001	No Encoder Pulses
1002	Unexpected Stall, Main Drive
1003	Run Time Too Long, Main Drive
1010	Main drive unable to unwind after stall
14001	Message Queue Full
15003	Run Time Too Long, Bypass Drive
15010	Run Time Too Short, Bypass Drive Could Not Drive Offline
15011	Run Time Too Short, Bypass Drive Could Not Drive Online
16001	Communication Lost With Unit 2
16002	Communication Lost With Unit 3
16003	Communication Lost With Unit 4
18000	Reset Performed
18001	Power Loss
18002	Power Restored
20001	Run time too long, AUX drive
20002	Run time too short during unwind, AUX drive
20011	Run time too short, AUX drive
21XXX	System recovery from memory error

Troubleshooting Guide

Problem	Possible Cause	Solution
1. No Display on POD	<ul style="list-style-type: none"> a. No power at electric outlet b. Control valve Power Adapter not plugged into outlet or power cord end not connected to PC board c. Improper power supply d. Poor connection between POD connector and PC Board. e. Defective Power Adapter f. Defective PC Board 	<ul style="list-style-type: none"> a. Repair outlet or use working outlet b. Plug Power Adapter into outlet or connect power cord end to PC Board connection c. Verify proper voltage is being delivered to PC Board d. Check connector on POD, possible broken wire or terminal pin not inserted properly in connector. Clean pins on PC Board by plugging and unplugging the POD connector a few times to remove excess protective coating. e. Replace Power Adapter f. Replace PC Board
2. POD does not display correct time of day	<ul style="list-style-type: none"> a. Power Adapter plugged into electric outlet controlled by light switch b. Tripped breaker switch and/or tripped GFI c. Power outage d. Defective PC Board 	<ul style="list-style-type: none"> a. Use uninterrupted outlet b. Reset breaker switch and/ or GFI switch c. Reset time of day d. Replace PC Board
3. Display does not indicate that water is flowing. Refer to user instructions for how the display indicates water is flowing	<ul style="list-style-type: none"> a. Bypass/ isolation valve in bypass position b. Meter is not connected to meter connection on PC Board c. Restricted/ stalled meter turbine d. Meter wire not installed securely into three pin connector e. Defective meter f. Defective PC Board 	<ul style="list-style-type: none"> a. Turn bypass/isolation handles to place in service position b. Connect meter to three pin connection labeled FLOW on PC Board c. Remove meter and check for rotation or foreign material d. Verify meter cable wires are installed securely into three pin connector labeled FLOW e. Replace meter f. Replace PC Board
4. Control valve regenerates at wrong time of day	<ul style="list-style-type: none"> a. Power outage b. Time of day not set correctly c. Time of regeneration set incorrectly d. Control valve set at "on 0" (immediate regeneration) 	<ul style="list-style-type: none"> a. Reset time of day. b. Reset to correct time of day c. Reset regeneration time d. Check programming setting and reset to dEL (for a delayed regen time)
5. Time of day flashes on and off	<ul style="list-style-type: none"> a. Power outage occurred 	<ul style="list-style-type: none"> a. Test voltage of Lithium Coin Cell Battery (new battery 3.0v+, dead battery 2.75vdc). Replace battery if needed and reset time of day.
6. Control valve does not regenerate automatically when the REGEN button is depressed and held.	<ul style="list-style-type: none"> a. Defective PC Board b. For the case of systems, another unit in regen would not allow another unit to go into regeneration 	<ul style="list-style-type: none"> a. Replace PC Board b. Wait for unit in regeneration to finish

Troubleshooting Guide

Problem	Possible Cause	Solution
7. Control valve does not regenerate automatically but does regenerate when the REGEN button is depressed and held.	<ul style="list-style-type: none"> a. Bypass/isolation valves in bypass position b. Meter is not connected to meter connection on PC Board c. Restricted/ stalled meter turbine d. Incorrect programming e. Meter wire not installed securely into three pin connectors f. Defective meter g. Defective PC Board 	<ul style="list-style-type: none"> a. Turn bypass/isolation valve's handles to place in service position b. Connect meter to three pin connection labeled FLOW on PC Board c. Remove meter and check for rotation or foreign material d. Check for programming error e. Verify meter cable wires are installed securely into three pin connector labeled FLOW f. Replace meter g. Replace PC Board
8. Hard or untreated water is being delivered	<p>Check water quality directly at unit outlet</p> <ul style="list-style-type: none"> 1) Water quality is good <ul style="list-style-type: none"> a) Bypass/isolation valves are open or faulty 2) Water quality is poor <ul style="list-style-type: none"> a) Damaged seal/stack assembly b) Faulty riser tube or seal c) Control valve body type and piston type mis-matched 3) Media is exhausted, water quality is poor <ul style="list-style-type: none"> a) Higher than anticipated water usage b) Meter not registering c) No regenerant or low level of regenerant in regenerant tank d) Control fails to draw in regenerant e) Water quality fluctuation f) Fouled media bed 	<ul style="list-style-type: none"> 1) External Bypass Leak <ul style="list-style-type: none"> a) Fully close bypass/isolation valves or replace 2) Internal Bypass Leak <ul style="list-style-type: none"> a) Replace seal/stack assembly b) Verify seal placement & engagement with riser c) Verify proper control valve body type and piston type match 3) No internal leaks <ul style="list-style-type: none"> a) Check program settings or diagnostics for abnormal water usage b) See Troubleshooting Guide #3 c) Check refill setting in programming. Check refill flow control for restrictions or debris and clean or replace, check refill flow control rate for proper fill time. d) Refer to Troubleshooting Guide #12 e) Test water and adjust program values accordingly f) Replace media bed
9. Control valve uses too much regenerant	<ul style="list-style-type: none"> a. Improper refill setting or refill flow control is not sized properly b. Improper program settings c. Control valve regenerates frequently 	<ul style="list-style-type: none"> a. Check refill setting and check refill flow control for proper refill rate. b. Check program setting to make sure they are specific to the water quality and application needs c. Check for leaking fixtures that may be exhausting capacity or system is undersized

Troubleshooting Guide

Problem	Possible Cause	Solution
10. Residual regenerant being delivered to service	<ul style="list-style-type: none"> a. Low water pressure b. Plugged, fouled, or incorrect injector size c. Restricted drain line d. Damaged seal/ stack assembly or piston allowing leakage during draw e. Draw time too short f. Excessive refill g. Vacuum leak in draw line/elbow 	<ul style="list-style-type: none"> a. Check incoming water pressure – water pressure must remain at minimum of 25 psi b. Inspect and clean or replace injector, or replace injector with correct size for the application c. Check drain line for restrictions or debris and clean d. Check seal/stack assembly and piston for damage and replace e. Program proper draw time needed f. Program proper refill time needed g. Locate vacuum leak and fix
11. Excessive water in regenerant tank	<ul style="list-style-type: none"> 1) Tank is being overfilled <ul style="list-style-type: none"> a) Improper program settings b) Missing refill flow controller 2) Previous regenerant is not being drawn out 	<ul style="list-style-type: none"> 1) Excess from fill cycle <ul style="list-style-type: none"> a) Verify program settings b) Visual inspection / measure volume output into container 2) See Troubleshooting Guide #12
12. Control valve fails to draw in regenerant	<ul style="list-style-type: none"> a. Injector is plugged b. Faulty regenerant piston c. Regenerant line connection leak d. Drain line restriction or debris causes excess back pressure e. Drain line too long or too high f. Low water pressure g. Damaged seal/stack assembly 	<ul style="list-style-type: none"> a. Remove injector and clean or replace b. Replace regenerant piston c. Inspect regenerant line for air leak d. Inspect drain line and clean to correct restriction e. Shorten length and/or height f. Check incoming water pressure – water pressure must remain at minimum of 25 psi g. Inspect seal/stack assembly for damage and replace
13. Water running to drain	<ul style="list-style-type: none"> a. Power outage during regeneration or unit is currently in regeneration b. Damaged seal/stack assembly c. Piston assembly failure d. Drive cap assembly not tightened properly 	<ul style="list-style-type: none"> a. Upon power being restored, control will finish the remaining regeneration time. Reset time of day. b. Replace seal/stack assembly c. Replace piston assembly d. Re-tighten the drive cap assembly

Troubleshooting Guide

Problem	Possible Cause	Solution
<p>14. Err – 1001 = Control unable to sense motor movement</p>	<p>a. Motor not inserted fully to engage pinion, motor wires broken or disconnected</p> <p>b. PC Board not properly snapped into drive bracket</p> <p>c. Missing reduction gears</p> <p>d. Damaged or dirty reduction gear reflectors</p> <p>e. Faulty or dirty optics on back of PC board</p>	<p>a. Disconnect power, make sure motor is fully engaged, check for broken wires, make sure two pin connector on motor is connected to the two pin connection on the PC Board labeled REGEN. Press NEXT and REGEN buttons for about 3 seconds to resynchronize software with piston position.</p> <p>b. Properly snap PC Board into drive bracket and then Press NEXT and REGEN buttons for about 3 seconds to resynchronize software with piston position.</p> <p>c. Replace missing gears</p> <p>d. Clean or replace reduction gear</p> <p>e. Clean or replace PC Board</p>
<p>15. Err – 1002 = Control valve motor ran too short and was unable to find the next cycle position and stalled</p>	<p>a. Foreign material is lodged in control valve</p> <p>b. Mechanical binding</p> <p>c. Main white drive gear too tight</p> <p>d. Improper voltage being delivered to PC Board</p>	<p>a. Open up control valve and pull out piston assembly and seal/ stack assembly for inspection. Press NEXT and REGEN buttons for about 3 seconds to resynchronize software with piston position.</p> <p>b. Check piston and seal/ stack assembly, check reduction gears, check drive bracket and main drive gear interface. Press NEXT and REGEN buttons for about 3 seconds to resynchronize software with piston position. Check that pinion is not pressed up tight against motor.</p> <p>c. Loosen main drive gear. Press NEXT and REGEN buttons for about 3 seconds to resynchronize software with piston position. Verify free motion by rotating main drive gear by hand, driving piston in and out.</p> <p>d. Verify that proper voltage is being supplied. Press NEXT and REGEN buttons for about 3 seconds to resynchronize software with piston position.</p>

Troubleshooting Guide

Problem	Possible Cause	Solution
16. Err – 1003 = Control valve motor ran too long and was unable to find the next cycle position	<ul style="list-style-type: none"> a. Motor failure during a regeneration b. Foreign matter built up on piston and stack assemblies creating friction and drag enough to time out motor c. Drive bracket not snapped in properly and out of position enough that reduction gears and drive gear do not interface 	<ul style="list-style-type: none"> a. Check motor connections then Press NEXT and REGEN buttons for about 3 seconds to resynchronize software with piston position. b. Replace piston and stack assemblies. Press NEXT and REGEN buttons for about 3 seconds to resynchronize software with piston position. c. Snap drive bracket in properly then press NEXT and REGEN buttons for about 3 seconds to resynchronize software with piston position.
17. Err - 1010 = Main drive unable to unwind after stall	<ul style="list-style-type: none"> a. Mechanical binding b. Main white gear too tight 	<ul style="list-style-type: none"> a. Remove drive motor to see if white gear moves b. Hold white gear firmly and rotate counterclockwise to free up gear
18. Err - 14001 = Message queue full	<ul style="list-style-type: none"> a. LEAD PC Board did not receive a response from LAG units. 	<ul style="list-style-type: none"> a. Press NEXT and REGEN buttons for > 3 seconds to resynchronize software with piston position.
19. Err -15003 = MAV or NHWBP valve motor ran too long and unable to find the proper park position Motorized Alternating Valve = MAV No Hard Water Bypass = NHBP	<ul style="list-style-type: none"> a. Control valve programmed for ALT A or NHWBP without having a motorized drive securely connected to the 2-pin terminal labeled “BYPASS” on the main PC Board b. Poor wire connection c. Excess drag causing timeout before stall d. Motorized Bypass or MAV for NHBP motor not fully engaged with reduction gears 	<ul style="list-style-type: none"> a. Press NEXT and REGEN buttons for about 3 seconds to resynchronize software with piston position. Re-program valve to proper setting b. Remove power and check connection for Motorized Bypass or MAV for NHBP motor to PC Board two pin connection labeled BYPASS. Make sure wires in connector are inserted securely and no wires are broken. Clean pins on PC Board by plugging and unplugging the connector a few times to remove excess protective coating. Press NEXT and REGEN buttons for about 3 seconds to resynchronize software with piston position. c. Open Motorized Bypass or MAV for NHBP to check for obstructions d. Properly insert motor into casing, do not force into casing. Press NEXT and REGEN buttons for about 3 seconds to resynchronize software with piston position.

Troubleshooting Guide

Problem	Possible Cause	Solution
<p>20. Err – 15010 = Motorized Bypass or MAV for NHBP valve motor ran too short (stalled) while trying to drive off-line</p> <p>Motorized Alternating Valve = MAV</p> <p>No Hard Water Bypass = NHBP</p>	<p>a. Foreign material is lodged in Motorized Bypass or MAV for NHBP valve</p> <p>b. Mechanical binding</p>	<p>a. Open up Motorized Bypass or MAV for NHBP and check for foreign material. Press NEXT and REGEN buttons for about 3 seconds to resynchronize software with piston position.</p> <p>b. Check drive cap assembly or piston and seal/ stack assembly, check reduction gears, drive gear interface, and check Motorized Bypass or MAV for NHBP black drive pinion on motor. Press NEXT and REGEN buttons for about 3 seconds to resynchronize software with piston position.</p>
<p>21. Err – 15011 = Motorized Bypass or MAV for NHBP valve motor ran too short (stalled) while trying to drive online</p> <p>Motorized Alternating Valve = MAV</p> <p>No Hard Water Bypass = NHBP</p>	<p>a. Foreign material is lodged in Motorized Bypass or MAV for NHBP valve</p> <p>b. Mechanical binding</p>	<p>a. Open up Motorized Bypass or MAV for NHBP and check for foreign material. Press NEXT and REGEN buttons for about 3 seconds to resynchronize software with piston position.</p> <p>b. Check drive cap assembly or piston and seal/ stack assembly, check reduction gears, drive gear interface, and check Motorized Bypass or MAV for NHBP black drive pinion on motor. Press NEXT and REGEN buttons for about 3 seconds to resynchronize software with piston position.</p>

Troubleshooting Guide

Problem	Possible Cause	Solution
<p>22. # of units error: Communications has been broken with the unit specified in the error message. These errors are logged as 16K series errors as follows: 16001: error with unit 2 16002: error with unit 3 16003: error with unit 4 16004: error with unit 5 16005: error with unit 6 16006: error with unit 7 16007: error with unit 8 16008: error with unit 9 16009: error with unit 10 160010: error with unit 11 160011: error with unit 12 160012: error with unit 13 160013: error with unit 14 160014: error with unit 15 160015: error with unit 16</p>	<p>a. System is programmed for the wrong number of units or a LAG unit is in “error # of units” mode due to loss of power.</p> <p>b. Poor connection on PC Boards</p> <p>c. More than one unit has determined that it is the LEAD unit</p>	<p>1) Correct all errors on LAG units before attempting to reset error on LEAD unit</p> <p>a. Pressing any button while in the # of units error will enter the user into the setting screen. Adjust to the correct units for the system and press NEXT to exit the setup screen. Press NEXT and REGEN buttons for about 3 seconds to resynchronize software with piston position. Re-program valve to proper setting.</p> <p>b. Make sure wires in connector are inserted securely and no wires are broken. Clean pins on PC Board by plugging and unplugging the connector a few times to remove excess protective coating. Press NEXT and REGEN buttons for about 3 seconds to resynchronize software with piston position.</p> <p>c. Press NEXT and REGEN buttons for about 3 seconds to resynchronize software with piston position. Then re-program each valve to operate as a single individual unit. Re-program the control that is to be the LEAD unit and it will filter down the programming to the LAG units automatically.</p>
<p>23. Err – 18000 = Reset was performed, this error code will display in the diagnostics under the error log</p>	<p>a. Reset performed.</p>	<p>a. You can view dates and times resets were performed</p>
<p>24. Err – 18001 = Power loss, this error code will display in the diagnostics under error log</p>	<p>a. When power is lost a signal is sent to log the power loss</p>	<p>a. You can view dates and times when power outage occurred</p>
<p>25. Err – 18002 = Power restored, this error code will display in the diagnostics under error log</p>	<p>a. When power is restored a signal is sent to log the power being restored</p>	<p>a. You can view dates and times when power outage occurred</p>

Troubleshooting Guide

Problem	Possible Cause	Solution
26. Err – 20001 = AUX motor ran too long while trying to find proper park position.	<ul style="list-style-type: none"> a. Control valve programmed for NHBP or Separate Source without having a motorized drive securely connected to the 2-pin terminal labeled “AUX” on the main PC Board b. Poor wire connection c. Mechanical binding d. Motorized MAV for NHBP motor not fully engaged with reduction gears, should be flush top of gear cover. 	<ul style="list-style-type: none"> a. Press NEXT and REGEN buttons for about 3 seconds to resynchronize software with piston position. Then re-program valve to proper setting b. Remove power and check connection for MAV or NHBP motor to PC Board two pin connection labeled “AUX”. Make sure wires in connector are inserted securely and no wires are broken. Clean pins on PC Board by plugging and unplugging the connector a few times to remove excess protective coating. c. Press NEXT and REGEN buttons for about 3 seconds to resynchronize software with piston position. d. Properly insert motor into casing, do not force into casing twist while inserting. Press NEXT and REGEN buttons for about 3 seconds to resynchronize
27. Err – 20002 = AUX motor ran too long during unwind.	<ul style="list-style-type: none"> a. When Aux motor ran into stall it did not unwind to relieve the stress on the pistons position. 	<ul style="list-style-type: none"> a. Press NEXT and REGEN buttons for about 3 seconds to resynchronize software with piston position.
28. Err – 20011 = Motorized MAV or NHBP valve motor ran too short (stalled) while trying to drive online	<ul style="list-style-type: none"> a. Foreign material is lodged in MAV or NHBP valve b. Mechanical binding 	<ul style="list-style-type: none"> a. Open MAV or NHBP and check for foreign material. Press NEXT and REGEN buttons for about 3 seconds to resynchronize software with piston position. b. Check main drive assembly, remove motor and be sure white gear turns freely.
29. Err – 21xxx = System auto recovery from memory location errors	<ul style="list-style-type: none"> a. Memory location verifications were corrected 	<ul style="list-style-type: none"> a. You can view dates and times these occurred.

This page intentionally left blank.

A. O. Smith Commercial Limited Warranty

WHO IS COVERED

This limited warranty is provided by A. O. Smith and applies only to the original owner who purchased and installed the A. O. Smith product for use at the original installation site. This warranty is non-transferable.

WHAT IS COVERED

This warranty covers defects in materials or workmanship in your A. O. Smith product when properly installed, used under normal operating conditions, and maintained according to A. O. Smith guidelines and local plumbing codes.

WARRANTY COVERAGE PERIODS

All warranty coverage periods run from the date of purchase, or 60 days after the date of manufacture if the purchase date cannot be verified.

For a period of FIVE YEARS: The control valve and all internal components.

The salt storage container.

Fiberglass mineral tank except damages due to freezing, high pressure (120 psi and above), extreme temperature (100°F and above) or a vacuum on the system.

For a period of ONE YEAR: All other softener components.

This warranty does not cover any equipment purchased for use in applications in which the product is not suited. It is the responsibility of the buyer to determine if a product is suitable for a particular application.

WHAT A. O. SMITH WILL DO

If a component is found defective during its warranty period, A. O. Smith will repair or replace the defective part at its discretion with an identical part or a comparable part if an identical replacement is not available. The owner is responsible for freight charges from the factory and local dealer service or labor fees. The warranty period for any replacement will run for the balance of the original warranty period.

WHAT A. O. SMITH WILL NOT DO

A. O. Smith will not pay for labor to remove or reinstall parts, shipping damage, water damage resulting from system failure, dealer trip charges, unauthorized service, damage caused by failure to follow installation instructions, or replacement filters, media, or routine maintenance.

WHAT IS NOT COVERED

1. This warranty does not cover: damage caused by accident, misuse, neglect, fire, flood, freezing, or other acts of God, improper installation, alteration, vacuum damage, chemicals, operation outside specifications, cosmetic issues, non-A. O. Smith parts, installation costs, improper plumbing connections, lack of maintenance, use with water that is microbiologically unsafe, loss of use, property damage, incidental or consequential damages, freight, or water damage. A. O. Smith disclaims all implied warranties to the fullest extent permitted by law.
2. Except when specifically prohibited by the applicable state law, the Owner, and not the Manufacturer, shall be liable for and shall pay for all charges for labor or other expenses incurred in the removal, repair or replacement of any component part(s) claimed to be defective or any expense incurred to remedy any defect in the product. Such charges may include, but are not necessarily limited to:
 - a. All freight, shipping, handling and delivery costs of forwarding a new component or replacement part(s) to the owner.
 - b. All costs necessary or incidental in removing the defective component part(s) and installing a new component part(s).
 - c. Any material required to complete, and/or permits required for, installation of a new component or replacement part(s).
 - d. All costs necessary or incidental in returning the defective component part(s) to a location designated by the Manufacturer.
 - e. This warranty provides specific legal rights and limitations, but you may have other rights under applicable state law.

OWNER RESPONSIBILITIES

Owners must install and operate the system per A. O. Smith specifications, comply with local codes, prevent freezing or vacuum damage, operate within pressure/temperature limits, replace media/filters as required, use only approved components, and retain proof of purchase and installation date. Either proof of purchase from an authorized dealer or proof of serial number, along with proof of proper installation, will be required to obtain warranty coverage.

HOW TO OBTAIN SERVICE

If service is required, contact your installation dealer or an authorized A. O. Smith dealer. If unavailable, ship the defective component (freight prepaid) to: **A. O. Smith, 1000 Prospect Ct., Appleton, WI 54914**. A. O. Smith will return repaired or replaced parts freight collect. Registration is not required to be covered by this warranty.

LIMITATION OF REMEDIES

The owner's sole remedy is repair or replacement of defective parts. A. O. Smith is not liable for incidental, consequential, water, or property damages. Some states do not allow such limitations; in such states, these may not apply.

STATE LAW RIGHTS

This warranty provides specific legal rights; additional rights may vary by state.



1900 Prospect Court • Appleton, WI 54914
Phone: 920-739-9401 • Fax: 920-739-9406

